

INSTALLATION, OPERATION & MAINTENANCE MANUAL

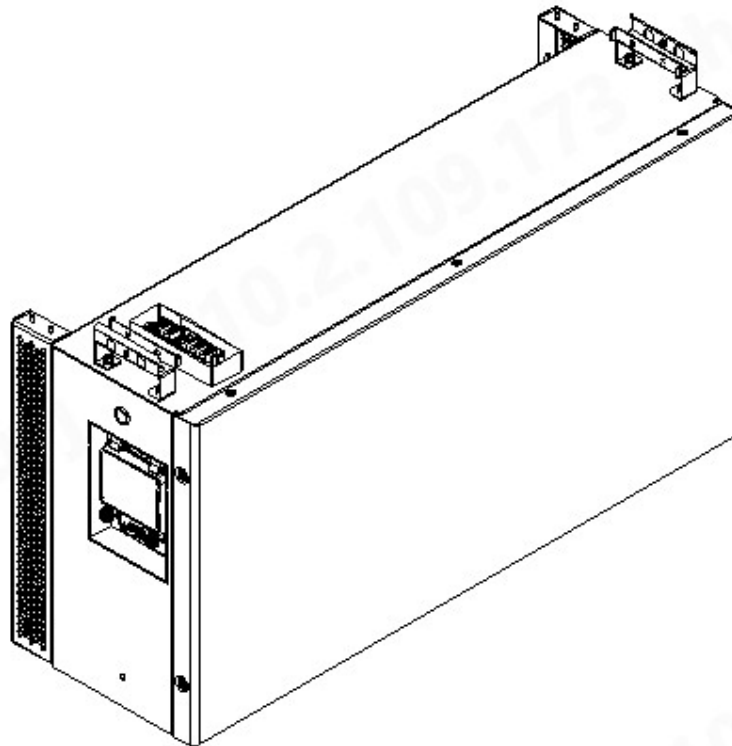

Model: BlueSpark BP48100 Series

Table of Contents

Table of Contents	1
Trademarks and Permissions	1
Software License.....	1
Disclaimer.....	1
1 About This Manual	3
1.1 Purpose.....	3
1.2 Intended Audience	3
1.3 Emergency Procedure	3
1.4 Conventions	5
1.5 Change History.....	6
2 Safety Instructions	5
2.1 Limitation of Liability	5
2.2 Warning Signs	6
2.3 Battery Safety	7
2.3.1 General Instructions.....	8
2.3.2 Maintenance of Battery Packs	9
2.3.3 Disposal of Battery Packs.....	9
2.4 Before Installation	10
2.5 Installation Safety.....	12
2.6 Operation Safety.....	14
3 Product Introduction.....	18
3.1 Features	18

- 3.2 Delivery Scope 19**
- 3.3 Battery Pack Model 20**
- 3.4 Battery Pack Appearance 21**
- 3.5 Battery Pack Schematic Diagram..... 22**
- 3.6 Parallel System..... 23**
- 3.7 Wiring Diagram..... 23**
- 3.8 Battery Pack States..... 23**
- 4 Installation 24**
 - 4.1 Battery Pack Installation Preparation 24**
 - 4.2 Preparing Tools and Instruments..... 27**
 - 4.3 Installation Position Requirements..... 28**
 - 4.3.1 Restricted locations 28**
 - 4.3.2 Residential barrier 29**
 - 4.4 Installing the Battery Packs..... 30**
 - 4.4.1 Battery installation 30**
 - 4.4.2 Connecting Battery Packs 32**
 - 4.4.3 Installing five to eight battery packs 34**
 - 4.4.4 Extension 5-8 Battery Pack Base Terminals and Wiring Instructions..... 34**
 - 4.4.5 Five to eight Battery Packs top cover installation instructions . 40**
 - 4.4.6 Five to eight Battery Packs installation drawing..... 40**
- 5 Operation 43**
 - 5.1 Indicator Lights and State 43**
 - 5.2 Power On 43**
 - 5.3 Shutdown procedure..... 44**
- 6 Maintenance 45**

6.1	Inspection Checklist for Users	45
6.2	Inspection Checklist for Professional Personnel.....	46
6.3	Troubleshooting	46
6.3.1	BMS Error codes and troubleshooting	47
6.3.2	BMS Protection codes and description	48
6.3.3	BMS Fault codes and description	48
7	Storing and Recharging Batteries.....	50
7.1	Storage Environment Requirements.....	50
7.2	Interval for Recharging Batteries	50
7.3	Recharging a Battery.....	51
8	Disposal	52
9	Specifications	53
10	Abbreviations	54

Legal Statement

© Shenzhen KSTAR New Energy Company Limited. 2025. All rights reserved.

All material appearing on this manual (“content”) is the property of Shenzhen KSTAR New Energy Company Limited (“KSTAR New Energy”). Distributing, copying, or forwarding any content to a third party or uploading any content to third-party platforms (such as publicly accessible websites) without prior permission of KSTAR New Energy is expressly prohibited.

Trademarks and Permissions

KSTAR and other KSTAR trademarks used in this manual are owned by Shenzhen KSTAR New Energy Company Limited.

All other trademarks or registered trademarks are the property of their respective owners.

Software License

KSTAR New Energy reserves all rights to the firmware and software. You may not use any of the data in the firmware or software for commercial purposes in any way.

Reverse engineering, decompiling, disassembling, adapting, implanting, or other derivative operations on the equipment are prohibited, as are researching the design and implementation of the equipment, obtaining the source code, infringing on intellectual property rights in any way, and disclosing the results of any performance tests.

Disclaimer

Before transporting, storing, installing, using, and/or maintaining the equipment, read this manual, adhere strictly to its prescriptions, and pay attention to the labels on the equipment. In this manual,

- “Equipment” refers to the hardware products, firmware, software, components, spare parts, and/or services to which this manual relates.
- “You” or “your” refers to an individual or a legal entity transporting, storing, installing, using, and/or maintaining the equipment.

In addition to paying proper attention to content in this manual labelled DANGER, WARNING, CAUTION, and NOTICE, you shall comply with relevant international, national, or regional standards, and industry practices. KSTAR New Energy shall not be liable for any damages resulting from violations of safety requirements or safety standards for the design, manufacturing, and use of the equipment.

KSTAR New Energy is not responsible for damage, personal injuries, death, and/or loss of or damage to property caused by use outside the scope of the conditions, technical specifications, or instructions provided in this manual.

Transport, storage, installation, use, maintenance, and all other operations shall comply with applicable laws and regulations, standards, and specifications.

KSTAR New Energy shall bear no liability in any of the following circumstances:

- The equipment is damaged due to earthquakes, floods, volcanic eruptions, mudslides, lightning strikes, fires, wars or armed conflicts, typhoons, hurricanes, tornadoes, extreme weather, or other force majeure events.
- The equipment is used outside the scope of the conditions, technical specifications, or instructions provided in this manual.
- Installation and/or use do not comply with relevant international, national, or regional standards or regulations.
- The equipment is installed or operated by unqualified personnel.
- The equipment is operated in a manner not in accordance with the prescriptions of the instruction manual and safety labels.
- The equipment and/or software code is disassembled and/or modified without the permission of KSTAR New Energy.
- The equipment is damaged while being transported by you or a third party commissioned by you.
- The equipment is stored in conditions that do not meet the standards specified in this manual.
- In the course of operating or maintaining the equipment, you use your own materials and tools that do not meet the requirements of local laws, regulations, and standards.
- Damage is caused by you or a third party through negligence, willful misconduct, gross negligence, or mishandling, or for other reasons not attributable to KSTAR New Energy.

1 About This Manual

This manual contains important information on the transport, storage, installation, use, and maintenance of the equipment. Read this manual carefully before operation. You must use the equipment strictly in accordance with the instructions in this manual to prevent damage or loss to the equipment, persons, and/or property. Keep this manual for future reference.

1.1 Purpose

This manual is intended as:

- An introduction to the BlueSpark BP48100 Serise, lithium-ion battery pack.
- An installation and maintenance guide for qualified personnel and technicians working with the battery packs.
- An operating guide for qualified personnel, technicians, and users of the battery packs.

For more information, visit www.KSTAR.com or the websites of the component manufacturers.

1.2 Intended Audience

The intended audience of this manual is:

- The qualified professional personnel and technicians who install, operate, and maintain residential photovoltaic energy storage systems that include the BlueSpark BP48100 Serise battery pack.
- Users who need to view battery pack parameters.
- System integration solution providers.

1.3 Emergency Procedure

An emergency is a situation involving a major incident or the possibility of a major incident that cannot be handled according to normal procedures and requires immediate action to limit or address the consequences.

This section describes emergencies that may be encountered when you are using the BlueSpark BP48100 Serise battery and how to handle such emergencies.

(1) General Handling

If an emergency occurs, remember the following:

- The grid main switch that supplies power directly to the BESS must be turned off.
- All load switches in the BESS must be turned off.
- The battery switch must be turned off.
- If you want to open the inverter or the battery pack after the power is turned off, to prevent possible fatal personal injury, use a properly calibrated voltage

meter to measure the voltage at the input terminals, wait approximately 15 minutes until the DC link capacitors inside the battery pack is completely discharged, and then open the top cover to repair.

WARNING

Before operating the equipment, make sure that the BESS is not supplied with grid power.

(2) Potential Emergencies

Battery Leakage

If the battery pack leaks electrolyte, avoid contact with the leaking liquid or gas. If you contact with the leaking substance, take the measures listed in [Table 10-1](#) immediately.

Table 10-1 Measures to Solve Battery Leakage Emergency

Exposure	Measures
Inhalation	Evacuate contaminated area, and then seek medical attention.
Eye Contact	Flush eyes with running water for five minutes, and then seek medical attention.
Skin Contact	Wash affected area thoroughly with soap and water, and then seek medical attention.
Ingestion	Induce vomiting, and then seek medical attention.

(3) Fire or Explosion

If a fire occurs in the area where the battery pack is installed, take the following measures.

WARNING

Batteries can explode when heated over 150°C. Toxic gases can leak when a battery pack burns. DO NOT approach. However, because the batteries contain only a small amount of oxygen and all batteries are equipped with explosion-proof valves, battery explosions are unlikely to occur.

Table 10-2 Handling with Fire

Handling with Fire	Description
Fire Extinguishing Agent	A respirator is not usually required. If the fire is caused by a battery, use a specialized fire extinguisher such as Noves 1230, FM-200, or a dioxin extinguisher. If the fire is not caused by a battery, use a regular ABC extinguisher.

Extinguishing Instructions	<p>If a fire occurs while charging a battery, turn off the battery pack circuit breaker and turn off the charging power if it is safe to do so.</p> <p>If the battery pack is not on fire, the fire should be extinguished before the battery pack catches fire.</p> <p>If the battery pack is on fire, do not attempt to extinguish the fire. Instead, evacuate personnel immediately.</p>
Methods of Handling Accidents	<p>If the battery is in a dry environment, put the damaged battery in an isolated area and call the local fire department or service engineer.</p> <p>If the battery is in a wet environment, DO NOT touch anything if any part of the battery, such as the inverter or cables, is submerged. DO NOT use the submerged battery. Contact a service engineer.</p>

1.4 Conventions

The following symbols are used in this manual to highlight important information.



DANGER

Indicates a hazardous situation that, if not avoided, will result in death or severe injury.



WARNING

Indicates a hazardous situation that, if not avoided, could result in death or severe injury.



CAUTION

Indicates a hazardous situation that, if not avoided, could result in minor or moderate injury.



Indicates information that is considered important but is not hazard related, typically used for activities that result in property damage, but no personal injury.



Indicates an important tip that leads to the best results, but not safety or damage related.

1.5 Change History

Here is the change history of this manual.

Version	Date	Changes
1.0	November-2025	<ul style="list-style-type: none">Initial release.

2 Safety Instructions

All the safety instructions in this section help you transport, store, install, use, and maintain the equipment safely, so be sure to read and follow them. In addition to these safety instructions, you must comply with the requirements of international, national, or regional standards and regulations, and you are encouraged to follow industry best practices.

The equipment must be transported, installed, and maintained by trained professionals who fully understand how the equipment works, have sufficient training and experience in operating the equipment, and know the possible dangers and their levels. Trained personnel are those who have received relevant technical and safety training and have relevant experience. They know the possible dangers they may face when operating the equipment and how to take steps to minimize the dangers to themselves and others.

2.1 Limitation of Liability

KSTAR New Energy is not responsible, directly or indirectly, for any damage to the equipment or loss of property caused by the following:

- Disassembling and/or modifying the equipment, replacing parts, or modifying the software code without the permission of the manufacturer.
- Altering, repairing, and erasing serial numbers or seals by technicians not certified by the manufacturer.
- Installation and/or operation of the equipment by unqualified personnel.
- Installing the battery pack in any way that does not comply with standards or regulations.
- Failure to comply with local safety regulations. For example, in Germany, equipment must comply with VDE certification and in Australia it must comply with SAA certification.
- Operation of the equipment in an environment with insufficient ventilation.
- Use not in accordance with the instruction manual, technical specifications, and/or any other instruction provided.
- Use of your own materials and tools that do not meet the requirements of local laws, regulations, and standards.
- Failure to follow standard maintenance procedures.
- Earthquakes, floods, volcanic eruptions, mudslides, lightning strikes, fires, wars, armed conflicts, typhoons, hurricanes, tornadoes, extreme weather, or other force majeure events.

Additionally, KSTAR New Energy is not responsible, directly or indirectly, for:

- Damage sustained during transportation, including paint scratches caused by friction inside the package during transportation, and damage sustained while being transported by you or a third party commissioned by you. You must file claims with the shipping or insurance company when the container and/or the package is unloaded and the damage is confirmed.

- Any other damage caused by you or a third party through negligence, willful misconduct, or mishandling, or for other reasons not attributable to KSTAR New Energy.

2.2 Warning Signs

The warning signs and nameplates attached to the equipment contain important information to guide you in safe use of the equipment. DO NOT remove, obscure, or damage these signs. Make sure that these signs are always intact and fixed in their correct positions. If a warning sign is damaged, contact the manufacturer and have it replaced immediately by certified technicians.

You can see these warning signs attached to the equipment.



Indicates a hazardous situation that, if not avoided, can result in death or severe injury!



Indicates a hot surface. Contact can cause burns.



Indicates that you should read the user manual for instructions.

WARNING

After the equipment is unpacked,

- Check all the warning signs and nameplates on the equipment.
- If you find any damages to the warning signs and/or nameplates on the equipment, contact the manufacturer immediately and DO NOT install the equipment.

WARNING

Before disposal, make sure that all warning signs and nameplates are clearly visible and are not removed or obscured.

WARNING

When you instruct others in use of the equipment, and maintain and/or repair the equipment, follow these instructions to prevent inappropriate use or accidents caused by uninvolved persons:

- Place clear signs at the front and rear-level switches to prevent accidents caused by inappropriate switching.
- Place a warning sign or safety caution tape around the operating area.

2.3 Battery Safety

A rechargeable lithium-ion phosphate battery is used in the equipment. The battery complies with the provisions of “United Nations Recommendations on the Transport of Dangerous Goods, Manual of Tests and Criteria, Part III, Section 38.3”.

KSTAR New Energy shall not be responsible for:

- Damages to the battery caused by earthquakes, floods, volcanic eruptions, mudslides, lightning strikes, fires, wars, armed conflicts, typhoons, hurricanes, tornadoes, extreme weather, or other force majeure events.
- Direct damage caused by operation of the equipment in environments other than the intended operating environment. Indicators of inappropriate environments include, but are not limited to, excessively high or low operating temperatures, instability of the power grid, and frequent power outages.
- Damage, leakage, and/or rupture caused by inappropriate operation or failure to connect the battery pack in accordance with requirements.
- Damage caused by over-discharge of the battery due to the failure of operating personnel to promptly power up the battery after it has been connected to the system.
- Damage caused by prolonged non-use after installation.
- Damage caused by inappropriate parameters that you set.
- Accelerated battery capacity degradation caused by mixing of batteries, including, but not limited to, the mixing of batteries of different brands and mixing of batteries with different rated capacities.
- Battery damage caused by storing the battery in an unintended environment, such as in a humid, rain-prone environment.
- Loss of capacity or irreversible damage to the battery caused over-storage without recharging the battery in a timely manner.
- Damage caused by your or a third party’s failure to follow the requirements specified by the manufacturer, including, but not limited to, unauthorized relocation and installation of the battery packs.

KSTAR New Energy shall not be responsible for damage caused by:

- Frequent over-discharge of batteries caused by your inappropriate maintenance, on-site expansion, or long-term failure to fully charge.
- Lack of appropriate maintenance in accordance with the operating manual. Such battery maintenance should include, but is not limited to, regular checks of the battery terminal screws to verify tightness.
- Changing the battery usage scenario without the approval of the manufacturer.
- Unapproved connection of additional loads to the battery.
- Batteries exceeding the maximum storage life.
- Batteries exceeding the warranty period. Such batteries can pose hazards and it is not recommended that you continue to use them.

2.3.1 General Instructions

The chemical substances inside the battery are well sealed, so there is no physical danger of fire or explosion or chemical danger of hazardous material leakage at normal temperatures and pressure levels during handling. If the battery pack is exposed to fire, mechanical shock, decomposition, or increased electrical stress due to misuse, then leakage, release of harmful substances, and/or explosion can occur. The released substances can irritate the eyes, skin, and throat.

 DANGER

- Only trained professionals are permitted to handle
- leaking batteries.
- When handling leaking batteries, personnel must wear goggles, rubber gloves, gas masks, and protective clothing.
- When handling leaking batteries, personnel must first disconnect the equipment and then remove the leaking batteries.
- Batteries should be protected from the following:
 - Short circuit caused by live line maintenance or by shorting the positive and negative terminals of the battery.
 - Exposure to high temperature or heating equipment, such as direct sunlight, ignition sources, transformers, or heaters.
 - Squeezing by an external force or immersion in water or other liquids.
 - Over-charging or forced over-discharging.
 - Exposing battery terminals to other metal objects.
 - The use of incorrect battery types.

 WARNING

Batteries should be protected from the following:

- Malfunctions or short circuits caused by liquid entering the battery. Therefore, DO NOT install the battery pack under air conditioning outlets, ventilation vents, machine room outlet windows, water pipes, and other locations prone to water leakage.
 - Inverted, sideways, tilted, or stacked placement.
 - False connection of fastening screws of the copper row and/or the cable, which can cause excessive voltage drop or the generation of a large amount of heat at higher current, which could burn the battery.
-

2.3.2 Maintenance of Battery Packs

 DANGER

- DO NOT perform live line maintenance on the batteries to prevent short circuit.
- Use the specified type of battery during replacement.

 WARNING

- Do a regular check on the fastening screws of copper rows and/or cables. Make sure that they are tightened and free of rust, corrosion, or other foreign objects. If they are not, clean them.
-

2.3.3 Disposal of Battery Packs

 WARNING

- Before disposal, completely discharge the battery and consume the lithium metal inside the battery.
 - DO NOT treat unwanted batteries as ordinary waste.
 - DO NOT throw the battery pack into fire or place them in high temperature.
 - DO NOT dissect, pierce, or crush the batteries.
 - If a battery pack is deformed, broken, or leaking, discard it immediately regardless of how long it has been in storage.
-

2.4 Before Installation

 DANGER

- Follow the safety instructions in this manual to prevent personal injury and/or property damage.
 - During transportation, a certified ABC fire extinguisher with a capacity of at least 2 kg must be with the equipment.
 - Smoking is not permitted on or near the vehicle while loading or unloading.
 - Before installation, make sure that the equipment is free of any electrical connections.
 - Make sure that no water pipes are inside the wall on which the system is to be mounted.
-

 **WARNING**

- DO NOT transport equipment in severe weather such as lightning, rain, snow, or winds of force 6 or higher.
- If there is a fire, evacuate the building or equipment area and ring the fire alarm. DO NOT enter a burning building or equipment area.
- Choose an appropriate and safe place to install the equipment. This place must meet these requirements:
 - Temperature: For the battery pack. See [Specifications](#).
 - Relative humidity: 0–95% (No condensation).
 - NO flammable or explosive materials.
 - NOT accessible to children.
 - NO salt hazards.
 - Sheltered from direct sunlight or severe weather.
 - NOT subject to strong vibration or electromagnetic fields.
 - Well ventilated
 - NOT a living area.
- A distance of at least 30 mm must be maintained between the cable and a heat generating device or the periphery of a heat source area to prevent deterioration and/or breakage of the cable insulation caused by high temperature.
- DO NOT install the equipment that is infiltrated by moisture.
- DO NOT install the equipment with damaged enclosure and exposed to moisture.

 **CAUTION**

- Only qualified personnel are permitted to transport the equipment.
- Loading, unloading, installation, removal, and transportation of inverters and battery packs must be accomplished by two or more persons to prevent personal injury caused by accidental falling equipment.
- If lifting tools are used to lift the equipment, make sure that no one passes or stays under the equipment.

NOTICE

- Before installation, do a regular check and maintenance on the tools.

2.5 Installation Safety



- To avoid personal injury caused by the high voltage inside the equipment:
 - Use special insulated tools for wiring.
 - Read the warning signs on the equipment and follow their instructions.
 - Follow the safety instructions in this manual and other documents provided.
- Only trained professionals are permitted to install the equipment.
- Only qualified personnel are permitted to disassemble the safety features and to service the equipment.
- Only the personnel who have the special operation qualification required by national or local authorities are permitted to work in special scenarios such as electrical operation, work at heights, and operation of special equipment.
- Only KSTAR-approved professional personnel are permitted to replace the equipment or spare parts (including software).
- DO NOT power up the equipment before the installation is completed and confirmed by trained professionals.
- Avoid direct contact with the power supply equipment, as well as indirect contact through wet objects. Prevent other conductors from coming into contact with the power supply equipment. Measure the voltage at the point of contact before you touch any conductor surface or terminal, so as to avoid electric shock.
- Use appropriate measuring tools to make sure that the electrical parameters of the equipment meet the requirements. To prevent electric arcs or shocks, make sure that the connection and use of the equipment comply with the specifications.

**WARNING**

- DO NOT install equipment in severe weather such as lightning, rain, snow, or winds of force 6 or higher.
- If there is a fire, evacuate the building or equipment area and ring the fire alarm, or call the emergency services. DO NOT enter a burning building or equipment area.
- When tightening screws or bolts on products or terminals with tools, tighten to the specified torque to prevent damage to the equipment. The manufacturer shall not be responsible for such damage.
- DO NOT touch the equipment surface when the equipment is in operation. The housing gets hot, and touching it can result in burns.
- The cables used in the PV system must be of the right size, firmly connected, and well insulated.

**CAUTION**

- To prevent uninvolved persons from approaching the equipment, place highly visible warning signs or set up safety caution tape around the equipment.
 - DO NOT remove the equipment protection.
 - DO NOT ignore the danger, warning, caution, and notice text in the manuals and on the equipment.
-

2.6 Operation Safety

DANGER

- Follow the safety instructions in this manual to prevent personal injury and/or property damage.
- The person who operates the equipment must have necessary knowledge of the equipment, including the equipment components and how they work.
- The person who operates the equipment must have necessary knowledge of this manual.
- Only qualified personnel are permitted to disassemble the safety features and to service the equipment.
- Keep persons other than those operating the equipment away from the equipment.
- DO NOT operate the equipment in an environment where explosions can occur, or where the relative humidity is high.
- To prevent chemical burns caused by leakage of electrolyte or toxic gases from a damaged battery, operate the battery packs in accordance with the standard procedure. When the battery packs are operated in a standard manner, no leakage of electrolyte or generation of toxic gases can occur. However, if the battery packs are damaged or malfunction, it can leak electrolyte or generate toxic gases.

WARNING

- DO NOT operate equipment in severe weather such as lightning, rain, snow, or winds of force 6 or higher.
- DO NOT touch the equipment with wet hands.
- DO NOT put any heavy objects on the top of the equipment.
- DO NOT damage the equipment with sharp objects.

CAUTION

- To prevent uninvolved persons from approaching the equipment, place highly visible warning signs or set up safety caution tape around the equipment.
- During the operation of the equipment, if any risks are found that may lead to personal injury or equipment damage, stop the operation immediately, report to the person in charge, and take effective steps.

NOTICE

- In the event of exposure to the electrolyte, immediately flush the affected area with water and seek immediate medical attention.

2.7 Maintenance Safety

DANGER

- Follow the safety instructions in this manual to prevent personal injury and/or property damage.
 - Only trained professionals are permitted to maintain the equipment.
 - Only qualified personnel are permitted to disassemble the safety features and to service the equipment.
 - Keep persons other than those operating the equipment away from the equipment.
 - Wear personal protective equipment (PPE), including protective gloves and protective shoes.
 - DO NOT begin maintenance work on the equipment until it is turned off and fully discharged.
 - To avoid burns, DO NOT operate the equipment immediately after shutdown. After the equipment cools down, wear protective gloves to operate the equipment.
-

WARNING

- To prevent or to minimize potential damage caused by moisture, DO NOT repair or maintain the equipment in a wet environment.
-

CAUTION

- To prevent uninvolved persons from approaching the equipment, place highly visible warning signs or set up safety caution tape around the equipment.
-

2.8 Disposal Safety

 DANGER

- Only trained professionals are permitted to discard the equipment.

 WARNING

- Before disposal, make sure that all warning signs and nameplates are clearly visible and have not been removed or obscured.
 - To prevent property damage and personal injury, dispose of equipment in accordance with local regulations and standards.
-





3 Product Introduction

3.1 Features

The BlueSpark BP48100 Series is a residential energy storage battery pack with a rated voltage of 51.2V and a rated capacity of 5.12 kWh, which is usually combined with a matching inverter to form a residential energy storage system. In particular, the inverter has an enhanced insulation performance. Normally, the battery pack stores and releases electrical energy according to the inverter management system requirements. KSTAR New Energy provides a photovoltaic storage-monitoring platform to monitor and control electricity generation and storage when the battery pack is used with the matching inverter. Power generation, consumption, and storage can be grasped at any time and any place, and the information can be monitored and controlled remotely.

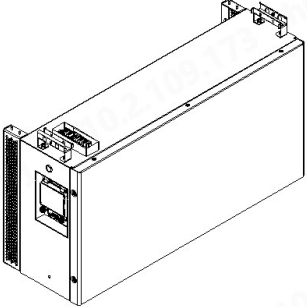
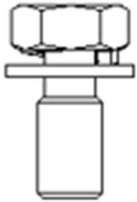
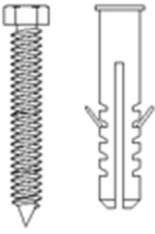
3.2 Delivery Scope

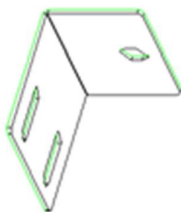
A battery pack delivery includes the following.:

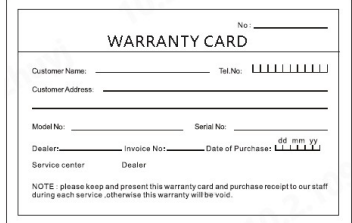
		
<p>Battery pack :1pcs</p>	<p>M5*12: 8pcs</p>	<p>ST6.3*50:2pcs D10*50:2pcs</p>
		
<p>M6 Gasket: 2pcs</p>	<p>M4*12: 2pcs</p>	<p>Mounting Kit- Wall : 2pcs</p>
		
<p>Mounting Kit- Battery:2pcs</p>	<p>Certificate of qualification: 1pcs</p>	<p>Warranty card guarantee card: 1pcs</p>

		
Mechanical cover:2pcs		

3.3 Battery Pack Model

Blue Spark BP48100 Series:

BP48100PF1A-G2-Px

- 1 “BP” means the label “BATTERY PACK”.
- 2 “48” means the voltage of the battery pack 48V.
- 3 “100” means the battery capacity is 100Ah.
- 4 “P” means the battery packs are connected in parallel for multiple battery packs.
- 5 “F” means with a heating film.
- 6 “1A” means with EVE 3U cells.
- 7 “G2” means the 2nd generation residential battery pack of KSTAR.
- 8 “P” means batteries parallel connection
- 9 “x” means the number of batteries parallel connection

3.4 Battery Pack Appearance

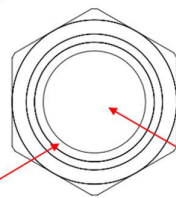
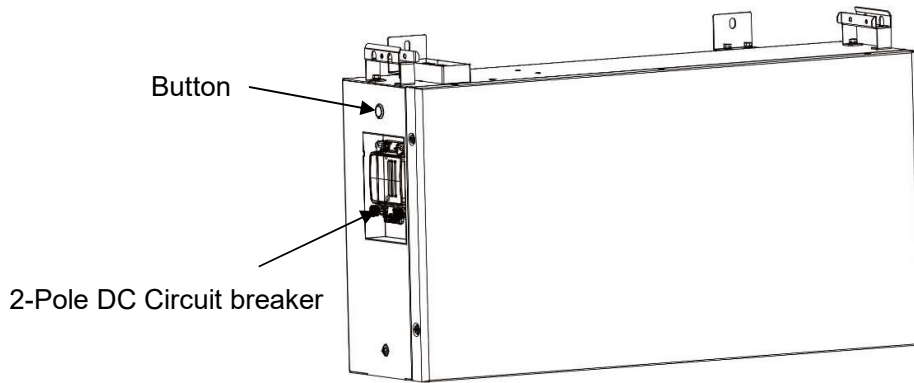

Indicator light
(Green indicates running and red indicates a fault)

Reset button
(Start, dormancy and reset are all realized by this Reset button)

AP15400A Male connector	
1	Battery-
2	Battery-
3	Chassis ground
4	CANH
5	Activate_5V+
6	NC
7	NC
8	DO_OP+
9	CANL
10	Activate_5V-
11	NC
12	NC
13	DO_OP-
14	Battery+
15	Battery+

Male connector serial number

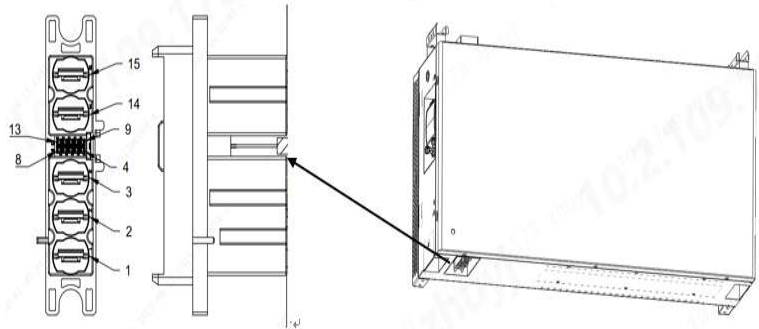

AP15400A Female connector	
1	Battery-
2	Battery-
3	Chassis ground
4	CANH
5	Activate_5V+
6	Inverter_key+
7	Inverter_Contact+
8	UP_IN+
9	CANL
10	Activate_5V-
11	Inverter_key-
12	Inverter_Contact-
13	UP_IN-
14	Battery+
15	Battery+

Female connector serial number

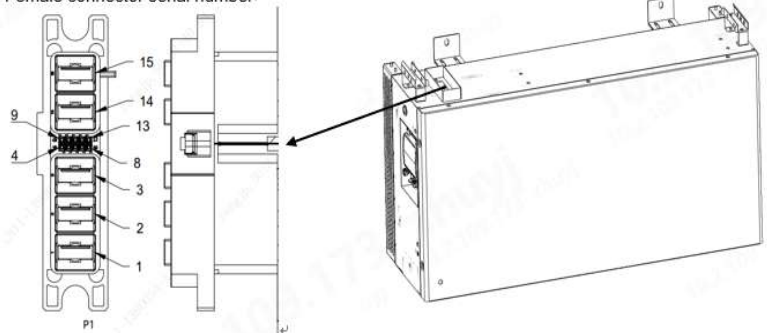

3.5 Battery Pack Schematic Diagram

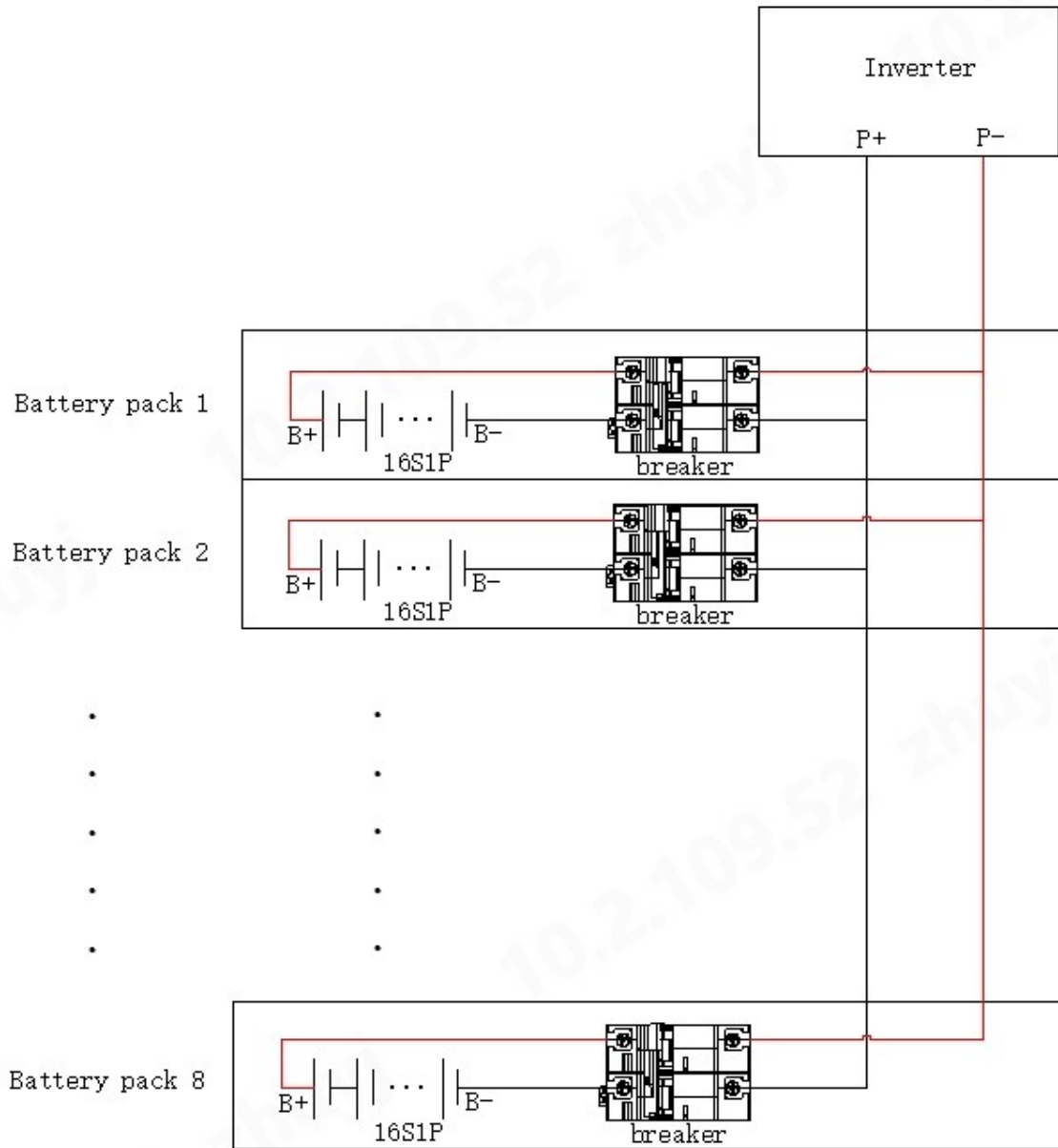

3.6 Parallel System

BP48100PF1A-G2 Configuration						
configuration	cell brand	whether with heating film or not	battery number in parallel	Rated capacity (KWh)	Max charging and discharging current(A)	Size(include base and head cover and decorative cover)(mm)
BP48100PF1A-G2	EVE	yes	1	5.12	80/80	725*465.5*245
BP48100PF1A-G2-P2	EVE	yes	2	10.24	160/160	725*835.5*245
BP48100PF1A-G2-P3	EVE	yes	3	15.36	240/240	725*1205.5*245
BP48100PF1A-G2-P4	EVE	yes	4	20.48	240/240	725*1575.5*245
BP48100PF1A-G2-P5	EVE	yes	5	25.6	240/240	1450*1357*245
BP48100PF1A-G2-P6	EVE	yes	6	30.72	240/240	1450*1357*245
BP48100PF1A-G2-P7	EVE	yes	7	35.84	240/240	1450*1727*245
BP48100PF1A-G2-P8	EVE	yes	8	40.96	240/240	1450*1727*245

3.7 Wiring Diagram





The battery power and signal connectors are in blind-inserted mode, so the communication was automatically connected after the battery packs and the inverter were assemble.

3.8 Battery Pack States

A battery pack can be in five states: OFF, NORMAL, ALARM, FAULT, and PROTECTION. For more information, see [Indicator Lights and States](#).

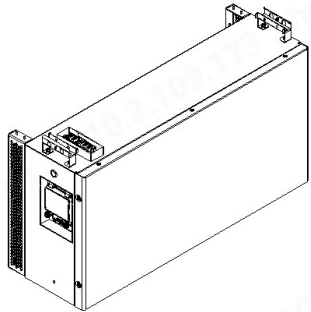
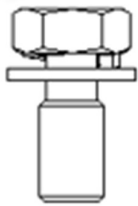
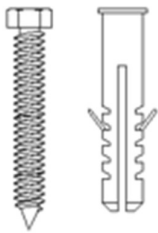
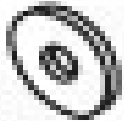
4 Installation



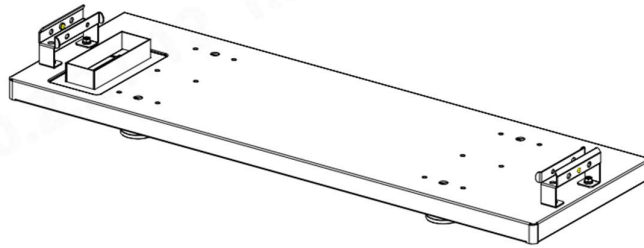

4.1 Battery Pack Installation Preparation

		
<p>Battery pack :1pcs</p>	<p>M5*12: 8pcs</p>	<p>ST6.3*50:2pcs D10*50:2pcs</p>
		
<p>M6 Gasket: 2pcs</p>	<p>M4*12: 2pcs</p>	<p>Mounting Kit- Wall : 2pcs</p>
		
<p>Mounting Kit- Battery:2pcs</p>	<p>Mechanical cover:2pcs</p>	

For a **single-tower** installation with 1 to 4 battery packs, use the matching base shown in the figure below. This base is **packed inside the inverter box**.

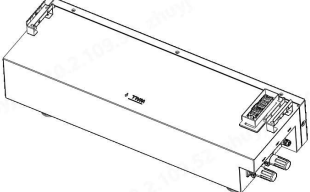
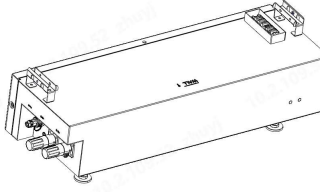
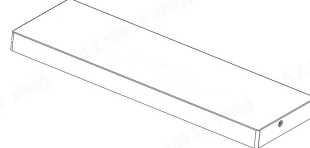





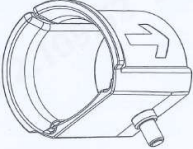
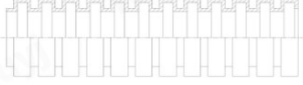

When installing 5 to 8 battery packs, two matching bases for 5-8 battery packs are used, and the base packed with the inverter will not be required. The 5-8 pack bases are included in the optional accessory kit, which must be purchased separately. The installation tool list for the optional accessory kit is shown in the table below.

		
<p>Right wiring base for 5-8 packs: 1pcs</p>	<p>Left wiring base for 5-8 packs: 1pcs</p>	<p>Top cover for 5-8 packs: 1 pcs</p>
		
<p>Positive connection wire : 1pcs(orange plug)</p>	<p>Negative connection wire: 1pcs(black plug)</p>	<p>Earth lead wire: 1pcs</p>

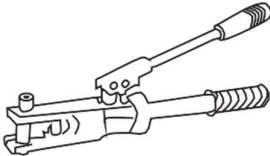
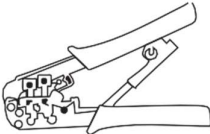
		
<p>Network cable: 1pcs</p>	<p>Power cable unlocking tool : 1pcs</p>	<p>φ 29mm corrugated tubes: 0.9M</p>

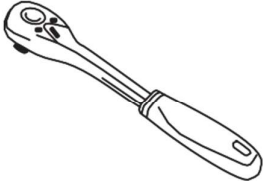
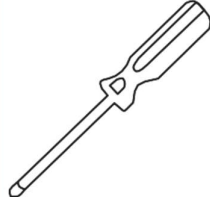
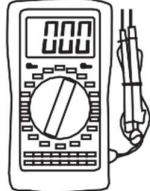
4.2 Preparing Tools and Instruments

 Protective Goggles	 Protective Gloves	 Protective Mask
 Protective Shoes	 Wire Clamp	 Cable Crimper
 φ10mm Power Drill	 Flat-head Screwdriver	 Torque Wrench
 Cross Screwdriver	 Multi-meter	 Rubber Mallet
 Leveling Instrument	 Tape Measure	 Marker Pen

4.3 Installation Position Requirements

The energy storage system composed of BlueSpark BP48100 Series batteries can be installed in an outdoor or indoor place. When installed indoors, the energy storage system must not be obstructed by any building structure, room furniture or equipment. The system is ventilated naturally. Therefore, the installation place should be clean, dry and fully ventilated. The installation place must be allowed to be accessed freely for installation and maintenance and the panel should not be covered.

Installation is not allowed in the following locations:

- (a) in restricted locations, as defined for switchboards in AS/NZS 3000;
- (b) within 600 mm of any exit;
- (c) within 600 mm of any vertical side of a window or building ventilation that ventilates a habitable room;
- (d) within 600 mm of any hot water unit, air conditioning unit or any other appliance not associated with the pre-assembled integrated BESS;
- (e) within 900 mm below any of the items included in Items (b), (c) and (d);
- (f) in ceiling spaces;
- (g) in wall cavities;
- (h) on roofs, except where specifically deemed suitable;
- (i) under stairways;
- (j) under access walkways; or
- (k) in an evacuation route or escape route.



Please ensure that indoor installation **strictly complies with** local regulations.

4.3.1 Restricted locations

DO NOT install the system in these locations:

- (a) no more than 600mm from any heat source (such as hot water heater unit, gas-fueled heater, air conditioning unit or any other equipment);
- (b) no more than 600mm from any exit;
- (c) no more than 600mm from any window or air vent;
- (d) no more than 600mm from the sides of other devices.



Please ensure that indoor installation **strictly complies with** local regulations.

When the energy storage system is installed indoors, make sure that the building structure, room furniture, and appliances do not interfere with the operation and maintenance of the system.

If the energy storage system is installed in a corridor, aisle, lobby, or similar area that leads to an emergency exit, at least one meter of space must be allowed for safe egress.

To prevent fire, the wall or structural surface on which the energy storage system is mounted must be made of non-combustible material. If the wall or structural surface is not made of non-combustible material, a layer of non-combustible material can be placed between the equipment and the surface.

4.3.2 Residential barrier

In order to prevent a fire from spreading in the space where the energy storage system is installed, install a non-combustible barrier on the side of the wall or structural surface with its other side installed with the energy storage system.

If the installation surface is not made of a non-combustible material, a non-combustible barrier can be installed between the energy storage system and the wall or structural surface.

If the energy storage system is installed on a wall or at a distance of 300mm from the wall that isolates the energy storage system from a residential space, the distance from other structures or objects must be increased. Be sure to keep the following distances:

- (i) at least 600mm between both sides of the battery;
- (ii) the interval between multiple units installed should be at least 300mm.

If the distance between the energy storage system and the ceiling or any object above it is less than 500mm, the ceiling or structural surface above must be made of non-combustible materials and its radius should be within 600mm.

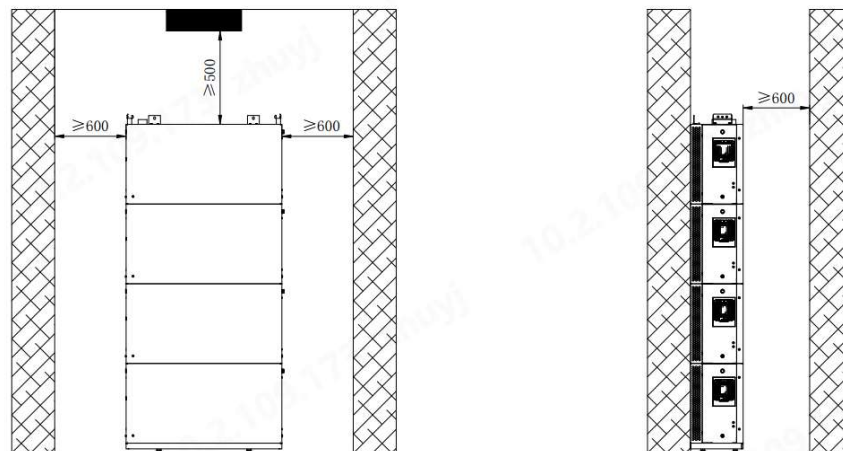

Installation distances from adjacent objects

4.4 Installing the Battery Packs

Follow the steps in this section to install the Battery Packs.

4.4.1 Battery installation

Battery Packs installed outdoor or indoor. Move the battery pack from the packaging box and mount it on the wall.

NOTES

- The battery pack should be moved by three persons. One battery pack weight more than 50 kg.
- Wear protective goggles and mask to prevent the dust created during drilling from entering the respiratory tract and eyes.
- Move the battery pack horizontally.

PROCEDURE

Step 1. First, we will introduce the installation of the 1-4 battery pack system. Place the matching base for 1-4 battery packs on the ground. Use a leveling instrument to make sure that the floor stand support is level. Recommended distance the base and the wall: 0-10mm if the wall is flat and even; 10-20mm if the wall is uneven.

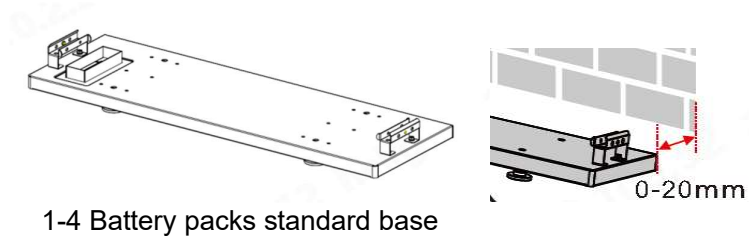

Step 2. Take the battery pack out of the carton and stand it horizontally on the ground, tear off the protective film at the battery interface on both sides of the battery pack, then place the battery pack vertically on the base.

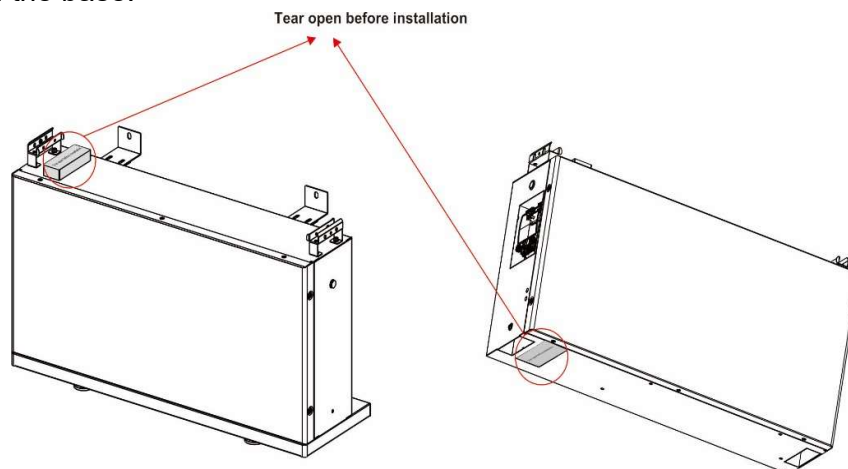

Step 3. First, screw the mounting kit-battery onto the battery pack, Then fix the

mounting kit wall to the mounting kit battery with screws. Finally, place the battery pack close to the wall for marking, drilling, installing expansion tubes and screws. M4*12 the screw torque is 1.6N·m, M5*12 the screw torque is 3N·m. Drilling use expansion tube, recommend drilling depth 55-60mm, drilling diameter 10mm.

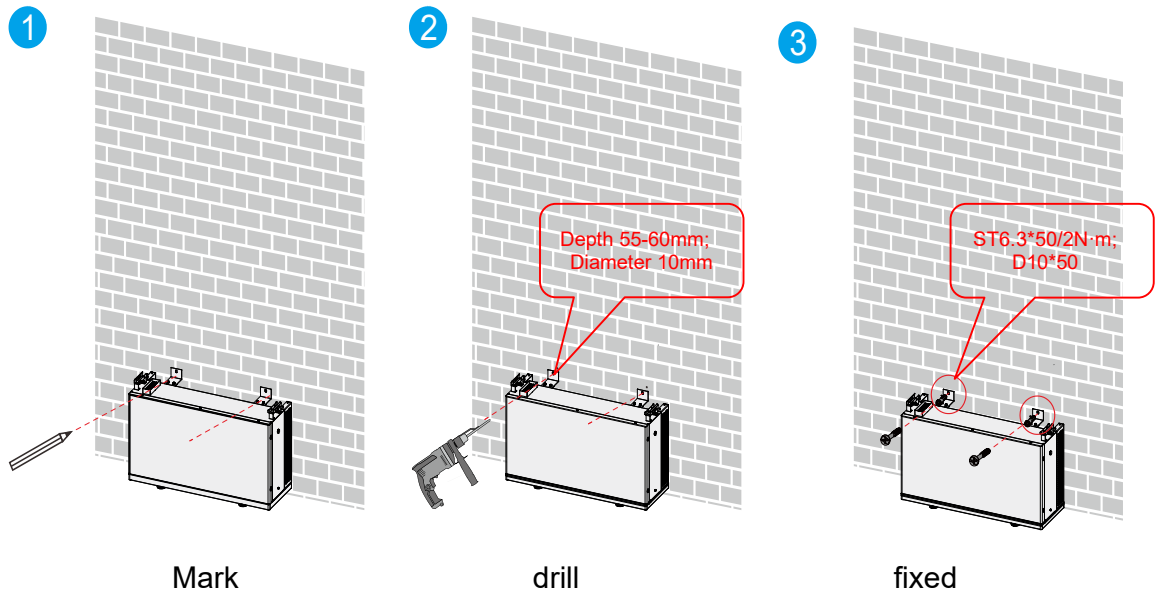
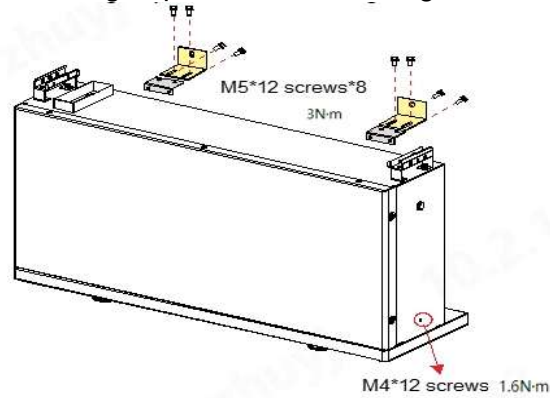

Step 4. Install a set of batteries and tighten the screws on both sides at the same time, then continue to stack the next battery module. Use M4*12 screws to tighten, the screw torque is 1.6N·m. When needing to assemble the second battery (and all others), repeat step 2-3 to carry out the installation.

After stacking the battery packs, install mechanical cover on both sides.

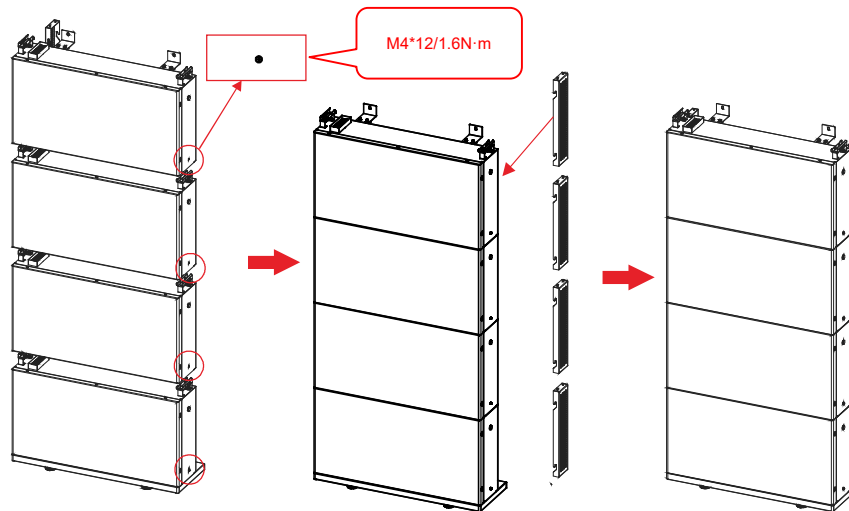

4.4.2 Connecting Battery Packs

The battery Protective Earthing (PE), DC Power and Communication are in blind-inserted mode, so the communication was automatically connected after the battery packs and the inverter were assembled within one stack (in case of 1-4 battery packs). For connection between battery stacks (in case of 5-8 battery stacks), the connection needs to follow the instructions in section 4.4.3~4.4.4.

After blind mating is completed, the battery system grounding will be connected to the top inverter via the chassis ground (refer to Figure 1 in Section 4.4.2 for terminal details). For the inverter grounding point, refer to Figure 2 in Section 4.4.2. Finally, connect the inverter's grounding point to the grounding busbar in the distribution box to complete the system grounding of the entire energy storage system.

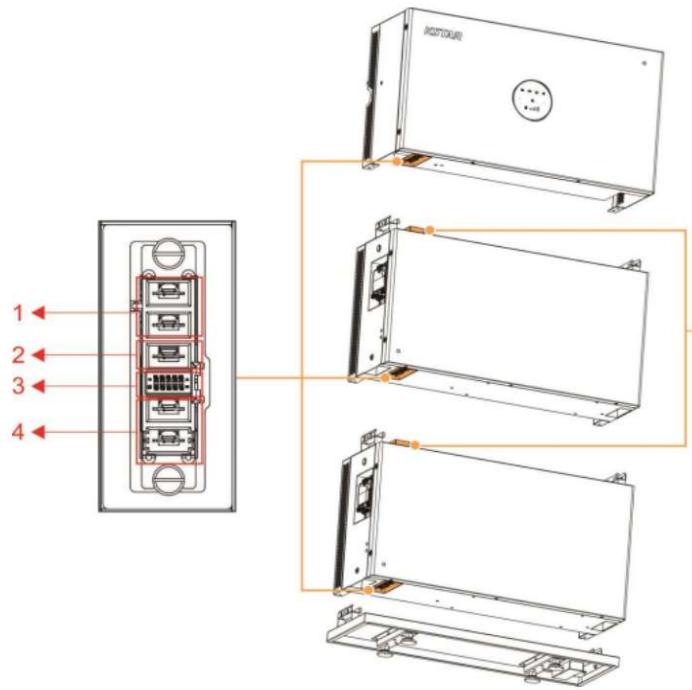

Code	Describe
1	Battery-
2	Chassis ground
3	Communication interface
4	Battery+

4.4.2 Figure 1 System Terminal Connection Diagram

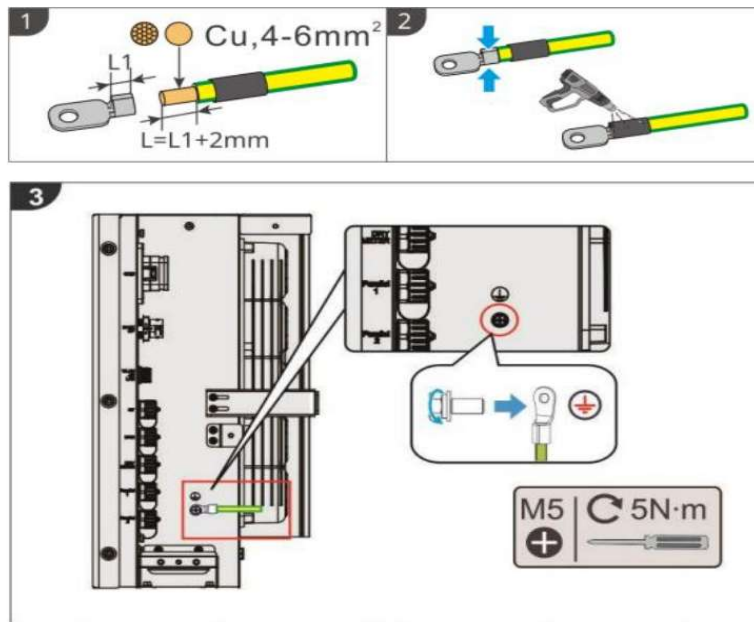

4.4.2 Figure 2 Grounding

4.4.3 Installing five to eight battery packs

When installing 5 to 8 battery packs, the system will consist of **two towers**. First, place the two 5-8 pack matching bases **symmetrically side by side** on the ground. Recommended distance the base and the wall: 0-10mm if the wall is flat and even; 10-20mm if the wall is uneven.



Right wiring base for 5-8 packs

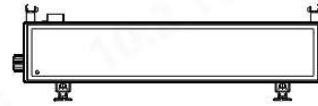

Left wiring base for 5-8 packs

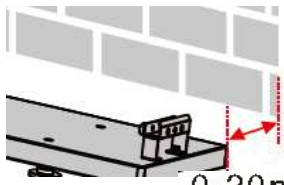

0-20mm

five to eight Battery Packs installing have two tower and four connecting lines

- ① Positive connection wire (black, 1/0AWG, 450mm, orange plug)
- ② Negative connection wire (black, 1/0AWG, 450mm, black plug)
- ③ Earth lead wire (yellow green, 8AWG, 500mm)
- ④ Network cable (black, 585mm)

4.4.4 Extension 5-8 Battery Pack Base Terminals and Wiring Instructions

4.4.4.1 Connecting Ports on base

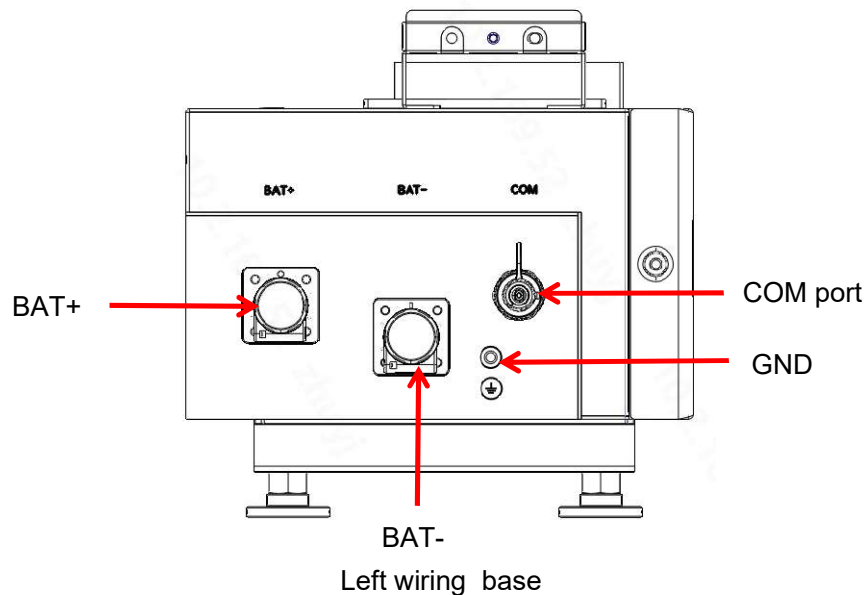

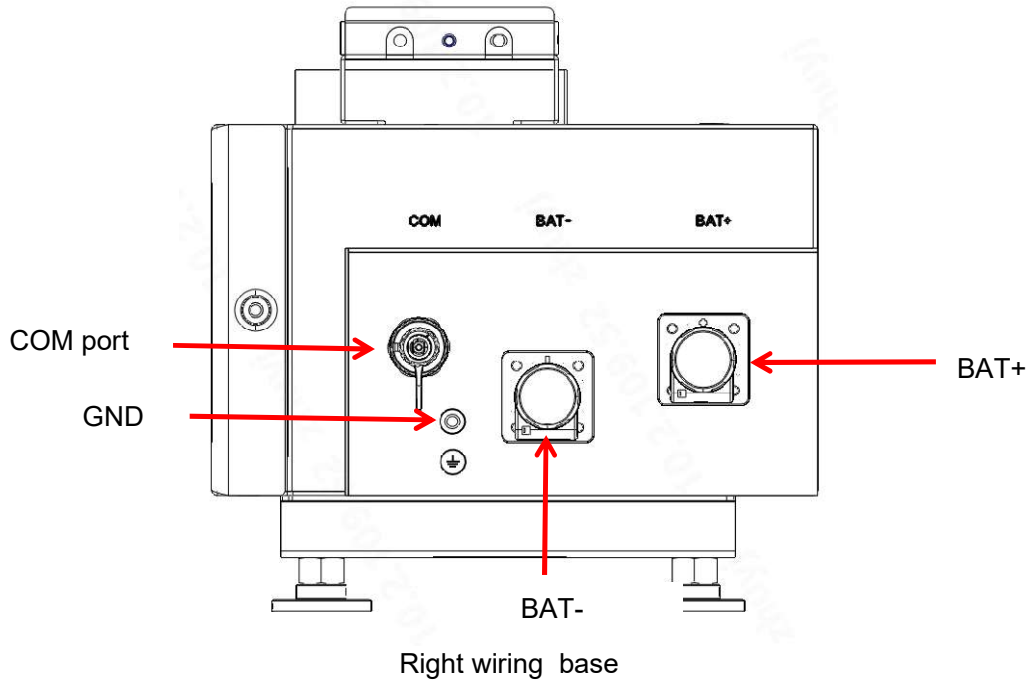

4.4.4.2 Wiring Instructions

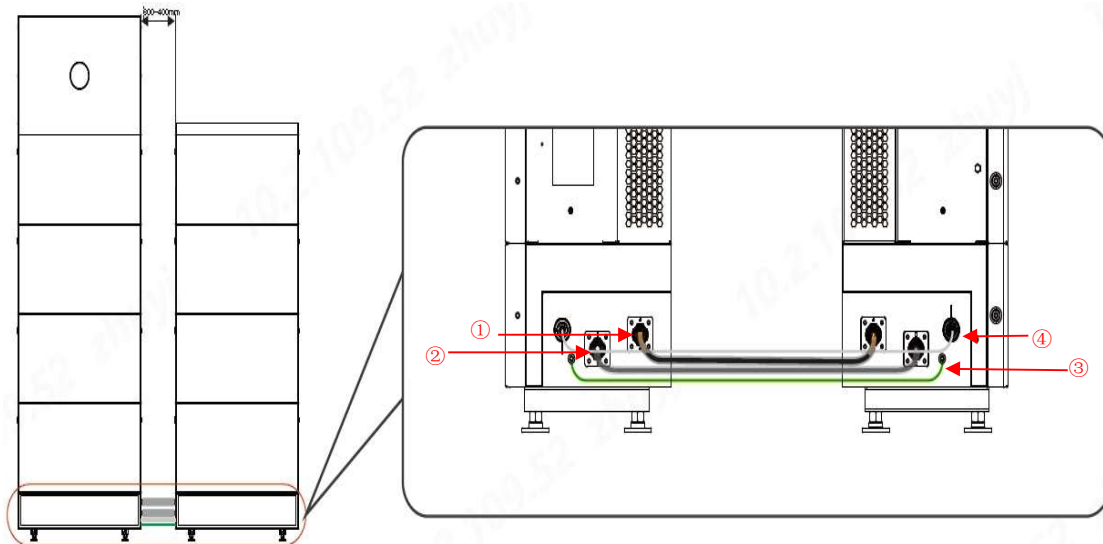

4.4.4.2.1 Battery bases wiring diagram

- ① Positive connection wire (black, 1/0AWG, 450mm, orange plug)
- ② Negative connection wire (black, 1/0AWG, 450mm, black plug)
- ③ Earth lead wire (yellow green, 8AWG, 500mm)
- ④ communication cable (black, 585mm)

The plugs on both ends of the four cables are identical. According to the positions marked in the base connection cable diagram (Section 4.4.4.2.1), insert both ends of the cables into the corresponding identical sockets on the two bases.

(1) Connect the positive power cable

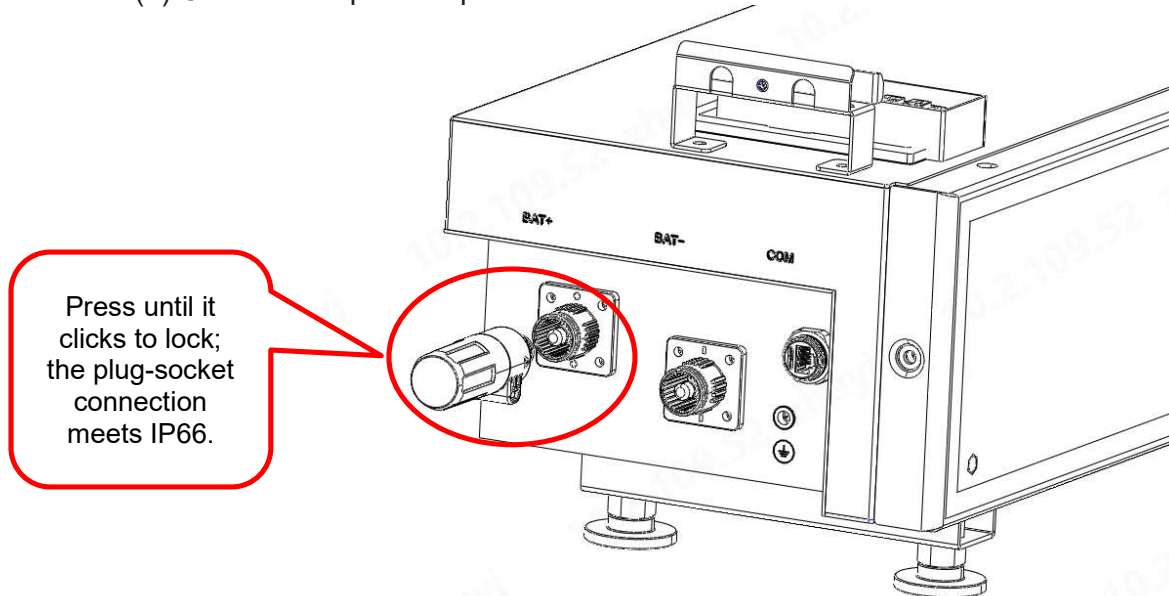

4.4.4.2.2 Positive power cable plug connection diagram

Note: Insert the positive plug directly into the positive socket; no alignment is required. The negative plug is the same. Reversed polarity cannot be inserted due to the keyed design.

(2) Connect the negative power cable

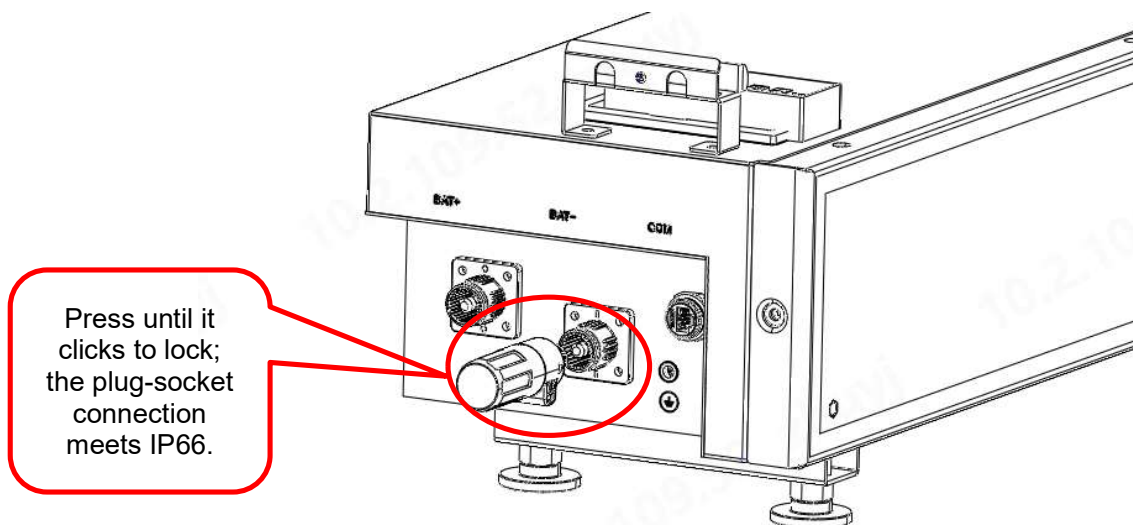

4.4.4.2.3 Negative power cable plug connection diagram

(3) Connect the communication cable

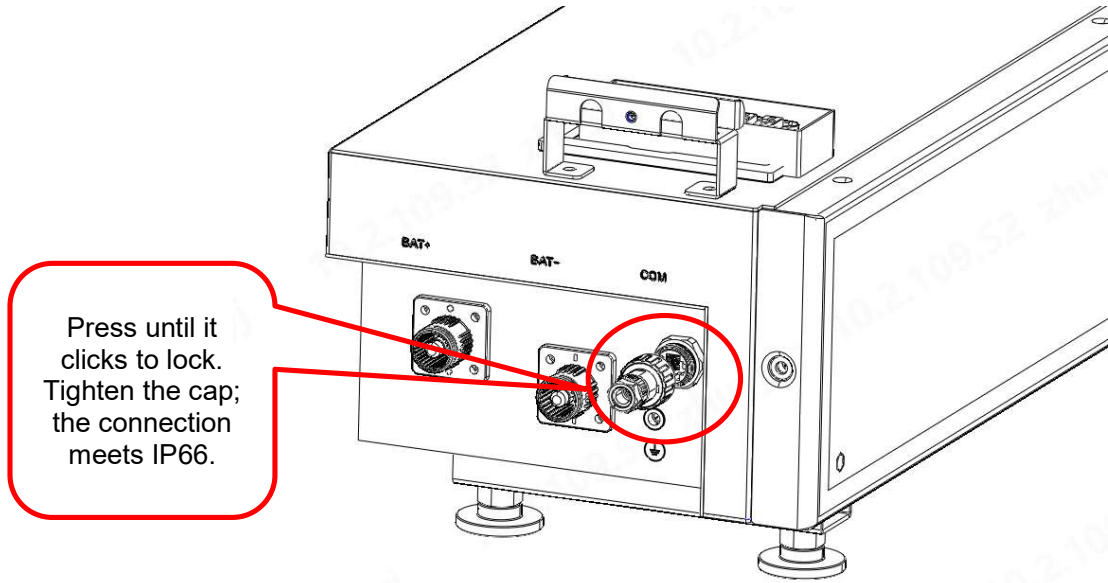

4.4.4.2.4 Communication cable plug connection diagram

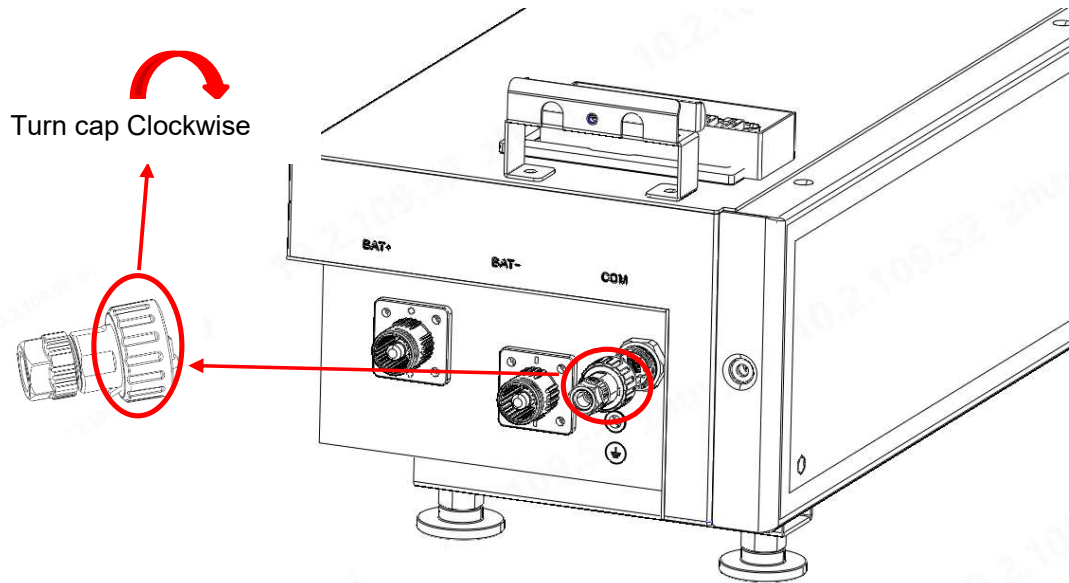

4.4.4.2.5 Communication cable plug protective cap tightening diagram

(3) Secure the grounding cable

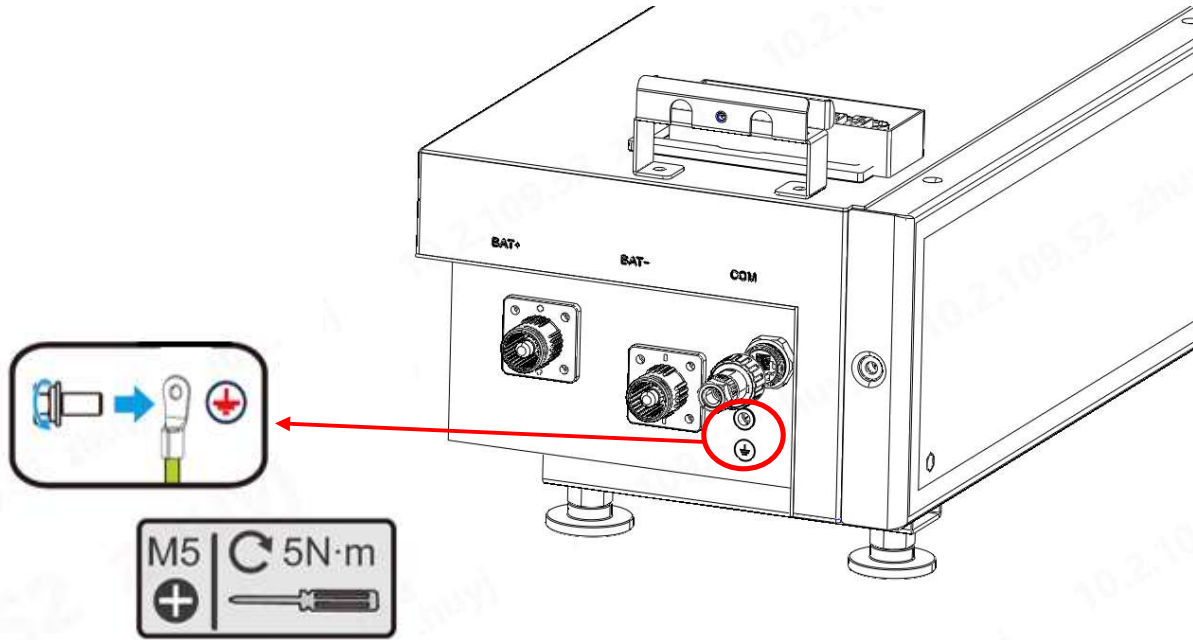

4.4.4.2.6 Grounding cable screw fastening diagram

4.4.4.3 Cable disconnection

(1) Power cable disconnection:

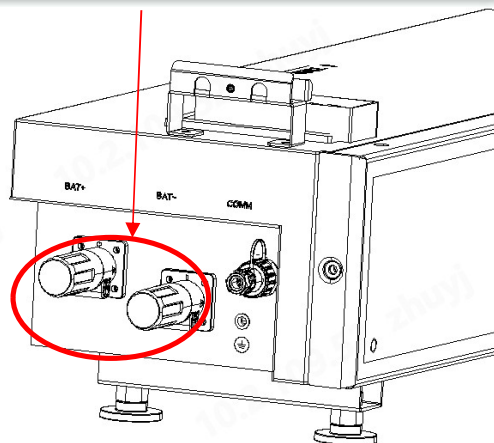
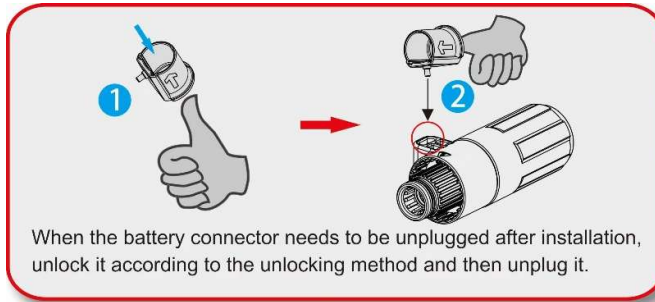

4.4.4.3.1 Power cable disconnection diagram

(2) Communication cable disconnection:

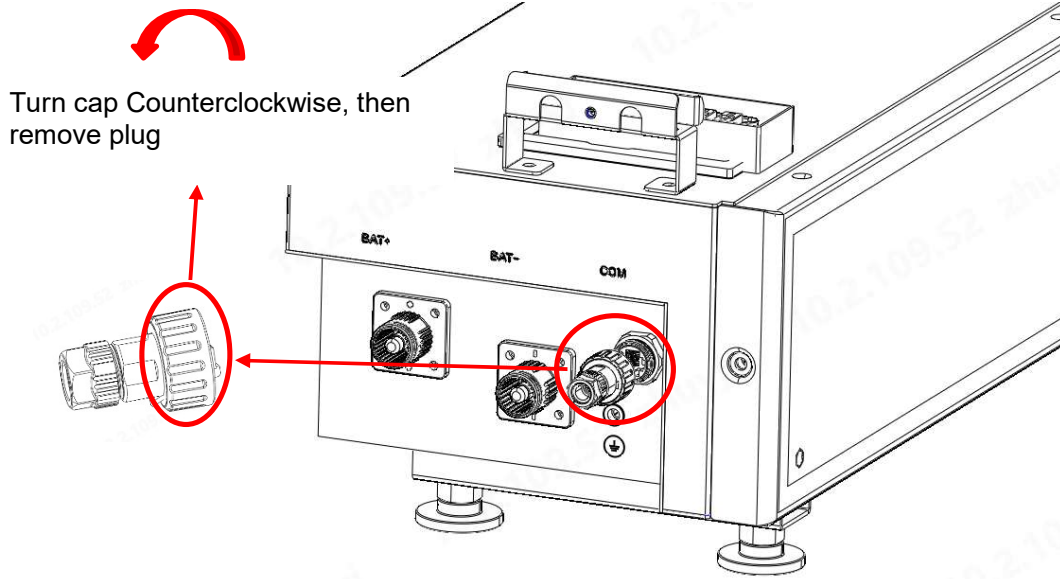

4.4.4.3.2 Communication cable disconnection diagram
(3) Grounding cable disconnection:

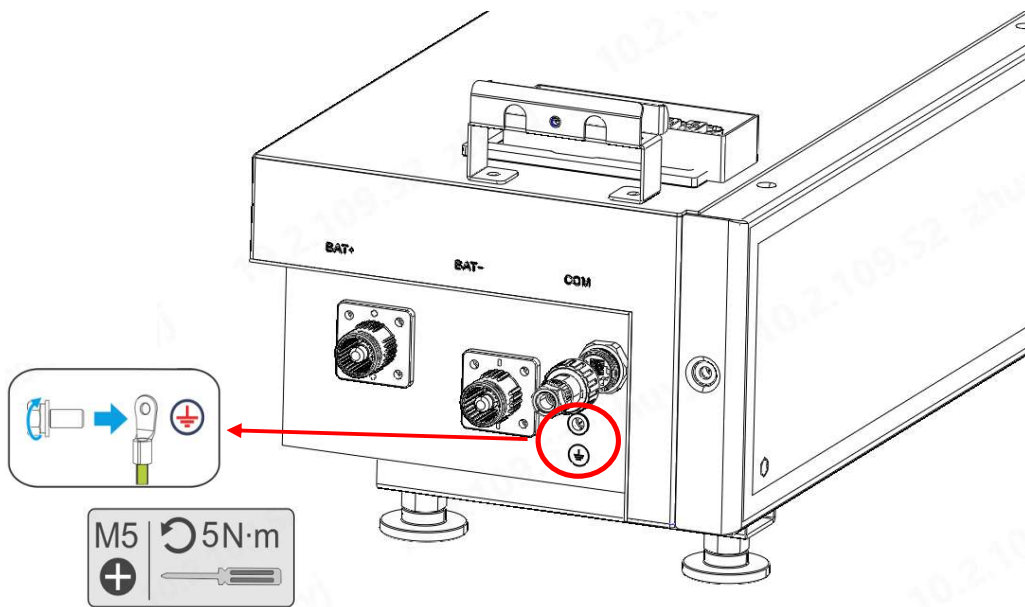

4.4.4.3.3 Grounding cable screw removal diagram

4.4.5 Five to eight Battery Packs top cover installation instructions

(1) Install the top cover

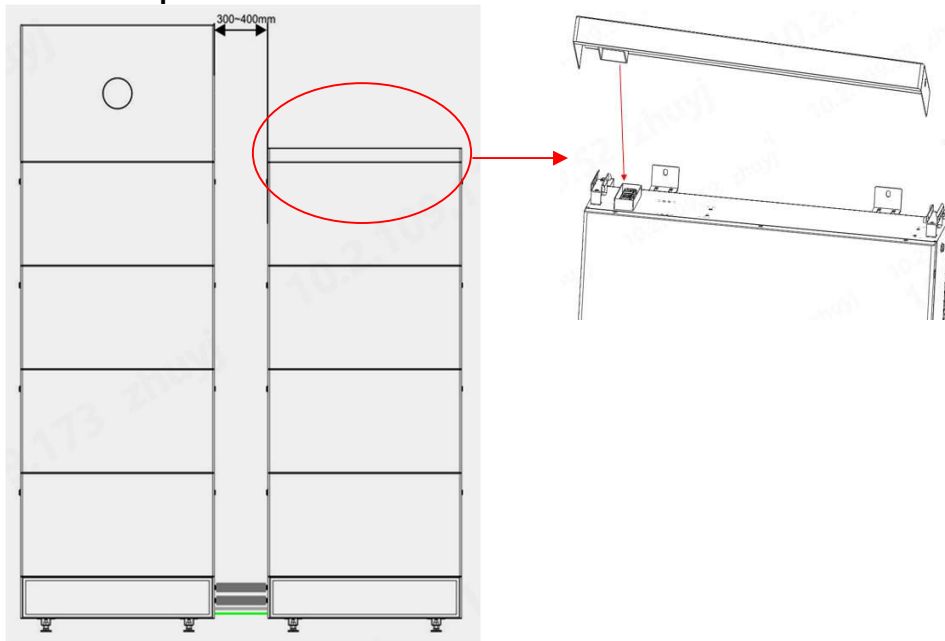

(2) Tighten the top cover fixing screws

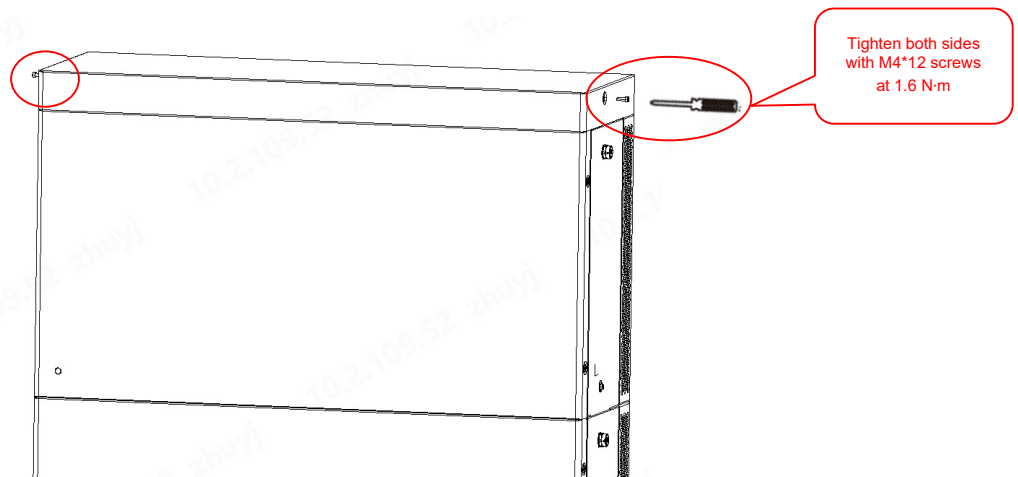

4.4.6 Five to eight Battery Packs installation drawing

Place the battery pack according to steps 2–4 in section 4.4.1.

NOTE:

The power lines need to be used by covering them with corrugated tubes.

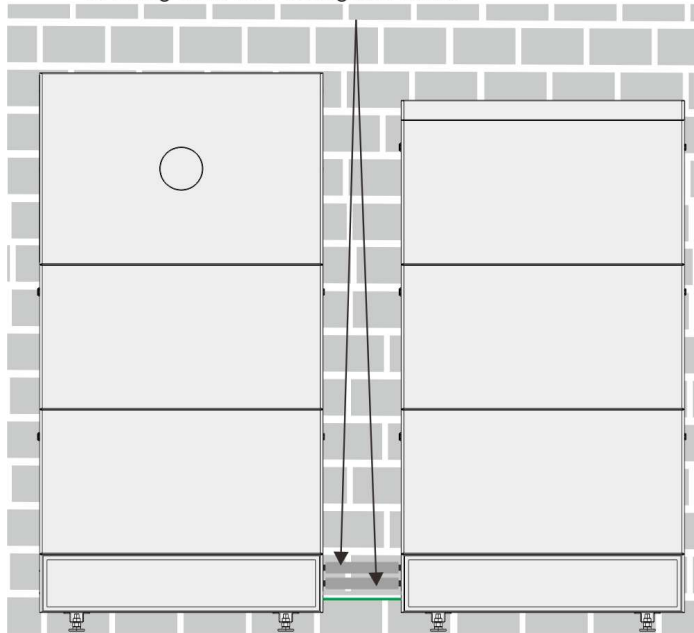

Five Battery Packs

The corrugated conduit included in the accessory pack is a split corrugated tube, which can be installed directly onto the cable by opening the slit. Additionally, the use of corrugated tubes must **comply with local regulations.**

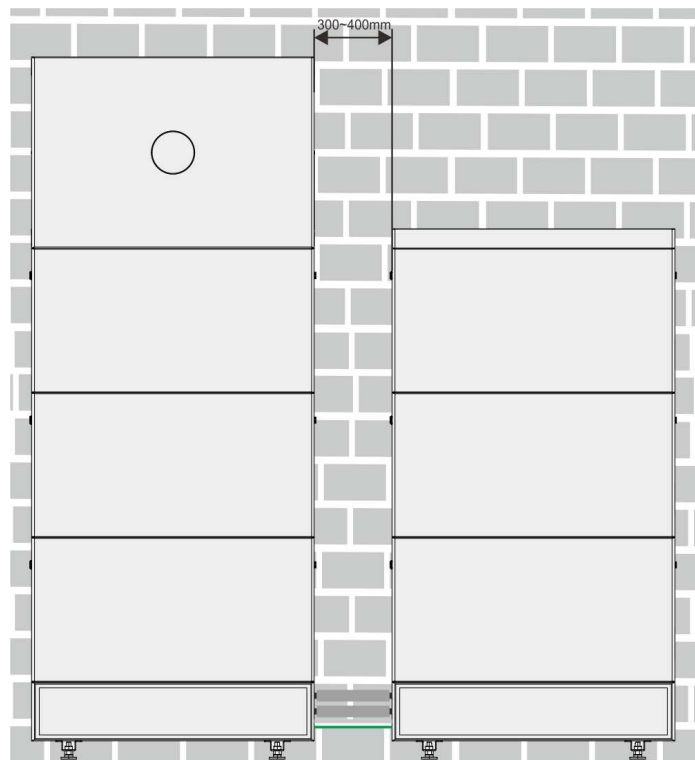

Six Battery Packs

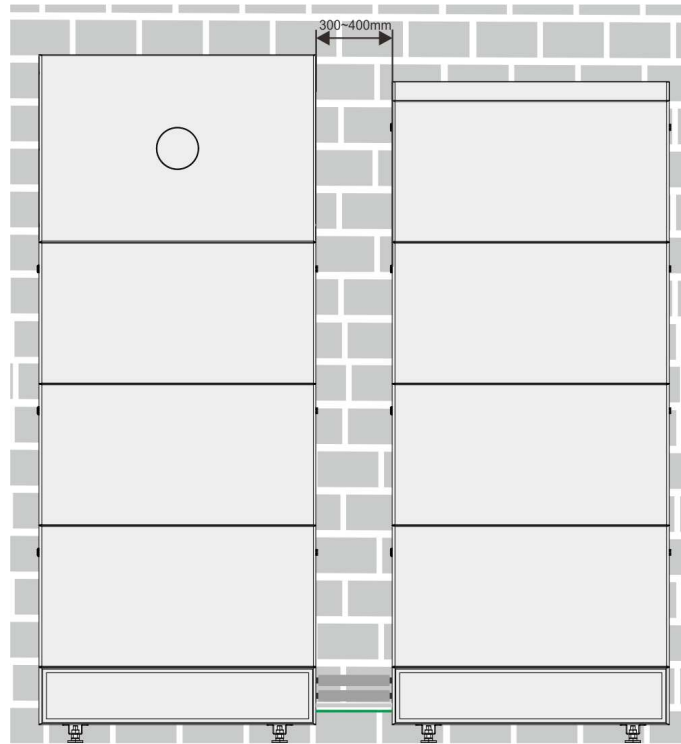

Seven Battery Packs

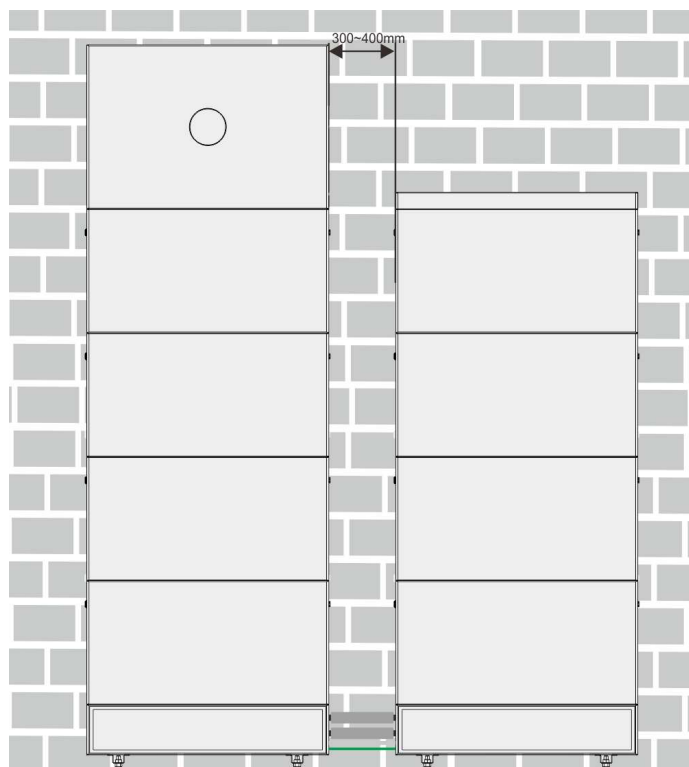

Eight Battery Packs

5 Operation

5.1 Indicator Lights and State

A battery pack can be in five states: **OFF**, **NORMAL**, **ALARM**, **PROTECTION**, and **FAULT**. In each state, the battery pack can operate in different modes.

There is an indicator light whose color is variable on the power button.

Product status	LED indicator status			
	LED color	LED blink status		
		Blink Mode	Blinking (Sec)	Off (Sec)
OFF	OFF	OFF all the time		
Normal	Green	ON all the time		
Alarm	Red	Blinks once every 1.5 seconds	0.75	0.75
Protection	Red	Blinks once every 0.5 seconds	0.25	0.25
Fault	Red	ON all the time		

5.2 Power On

Press the power button(1~3s) until the indicator light of the power button are on , then switch the 2-Pole DC Circuit breaker to the “ON”position.

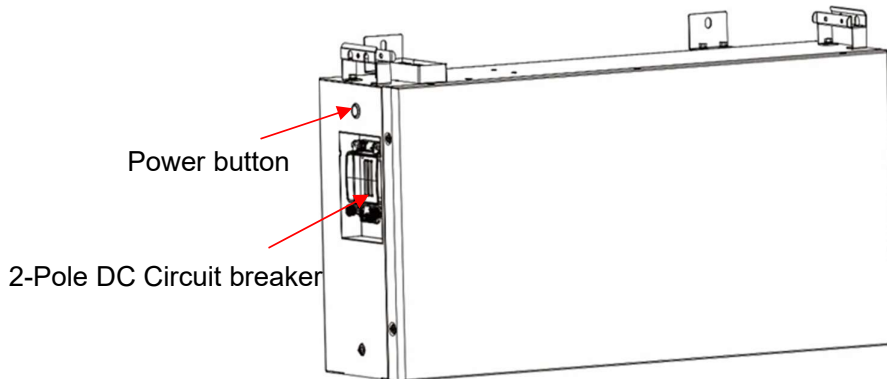

When multiple battery packs are connected in parallel, power on the battery packs in sequence, starting from the **First pack** below the inverter and continuing until the **Last pack** is

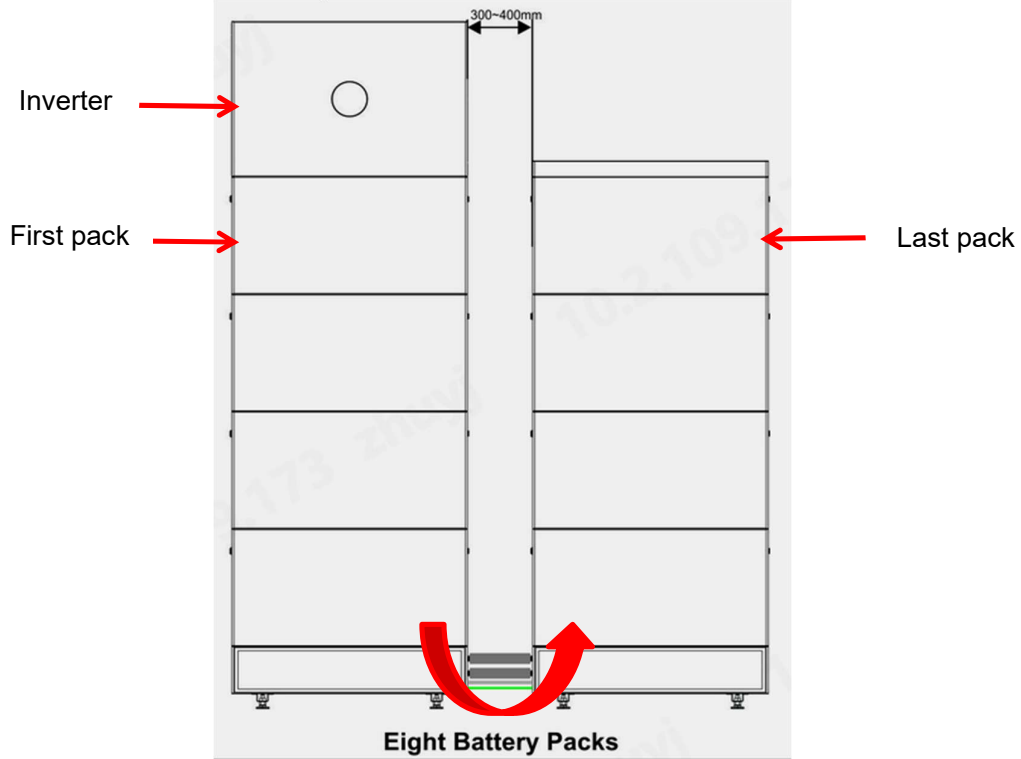

Power-on sequence diagram

5.3 Shutdown procedure

Press the power buttons (1~3s) until the indicator light of the power button goes out, then switch the 2-Pole DC Circuit breaker to the "OFF" position.

When multiple battery packs are connected in parallel, when a battery pack is shut down, it starts shutting down from the "Last pack" and proceeds in sequence until the "First pack" is shut down.

	<p>Precaution:</p> <p>Please make sure that the battery is not being charged or discharged before performing a shutdown.</p>
---	---

6 Maintenance

In this section, you can find the following:

- The inspection checklist for users of the energy storage system.
- The inspection checklist for professional personnel.
- Error codes, alarm codes, and the possible solutions of the system and the BMS.

6.1 Inspection Checklist for Users

Inspection Activity	Interval
Check for visible damage to any part of the system.	Six months
Check the battery packs for signs of wear and tear, heat damage, discoloration, and unusual smells.	Six months
Check the warning signs and guidance signs on the battery pack for signs of wear and damage, and make sure none have been removed or obscured.	Six months
Check whether any part of the system makes an abnormal noise when the system is running.	Six months
Monitor the temperature of the battery pack and clean the battery pack if necessary.	Six months to a year
Make sure that the ground around the system is clean and tidy.	Six months to a year
Check the maintenance access to make sure that it is clear and unobstructed.	Six months to a year
When the system is running, check the voltage, temperature, and other parameters of the battery packs.	Six months
Check the battery packs for ineffectiveness or damage.	Six months

6.2 Inspection Checklist for Professional Personnel

WARNING

- The equipment must be opened only by professional personnel that have been certified by KSTAR New Energy.
- During inspection and maintenance, wear protective personalequipment, including insulated gloves, protective shoes, and anti-noise earplugs.
- Follow local and international safety standards, regulations, and specifications to do the maintenance.
- Contact KSTAR New Energy promptly if you encounter anything not covered in this manual.

CAUTION

Before maintenance, disconnect all the electrical connections. Wait at least five minutes after disconnection, so that the residual voltage of the capacitors falls to a safe voltage. Use a multi-meter to make sure that the equipment is completely discharged.

Inspection Activities	Interval
Check electrical connections for looseness.	Six months to a year
Check cables for deterioration or damage.	Six months to a year
Check cable terminal screws for looseness.	Six months to a year
Check cable terminals for signs of overheating.	Six months to a year
Check the ground connection.	Six months to a year
Check whether the cable tie is attached to the cable.	Six months to a year
Check the EMS, SOLARMAN app, and other related equipment for failure or damage.	Six months to a year

6.3 Troubleshooting

When you see an error code or alarm code from CAN communication, you can find possible solutions in this section. If the problem persists after trying these solutions, please contact KSTAR New Energy or an authorized distributor.

When a problem is successfully solved, the error code or alarm code from CAN communication automatically disappears after a certain time delay, but you can always view it in the error records. For more information, see [Viewing INQUIRE](#).

6.3.1 BMS Error codes and troubleshooting

0x340 DATE2 , 3	Warning Flag	Troubleshooting
BIT0	Battery cell overvoltage alarm	The warning unit overcharging voltage is 3650mV, where the inverter should stop charging and the BMS should not turn off the charging MOS.
BIT1	Battery cell under-voltage alarm	The warning unit over discharging voltage is 2800mV, where the inverter should stop discharging and the BMS should not turn off the discharging MOS.
BIT2	Battery PACK overvoltage alarm	The warning overall overcharging voltage is 57.6V, where the inverter should stop charging and the BMS should not turn off the charging MOS.
BIT3	Battery PACK under-voltage alarm	The warning overall over discharging voltage is 44.8V, where the inverter should stop discharging and the BMS should not turn off the discharging MOS.
BIT4	Charging overcurrent alarm	The warning charging overcurrent is 100A, where the inverter should stop charging and the BMS should not turn off the charging MOS.
BIT5	Discharging the overcurrent alarm	The warning current of discharging overcurrent 1 is 100A where the inverter should stop discharging and the BMS should not turn off the discharging MOS. This alarm will automatically stop after 1min or when the charging current is greater than 1A.
BIT6	Reserved	
BIT7	Reserved	
BIT8	Charging high temperature alarm (cell temperature)	The protective limit of charging high temperature is 57°C where the BMS should forcibly turn off the charging MOS.
BIT9	Discharging high temperature alarm (cell temperature)	The warning discharging high temperature is 55 °C, where the inverter should stop discharging and the BMS should not turn off the discharging MOS.
BIT10	Charging low temperature alarm (cell temperature)	The warning charging low temperature is 2°C, where the inverter should stop charging and the BMS should not turn off the charging MOS.
BIT11	Discharging low temperature alarm (cell temperature)	The warning discharging low temperature is -18 °C, where the inverter should stop discharging and the BMS should not turn off the discharging MOS.
BIT12	High ambient temperature alarm	The warning high ambient temperature is 65°C, where the inverter should stop charging and discharging and the BMS should forcibly turn off the charging and discharging MOS.
BIT13	Low ambient temperature alarm	The warning low ambient temperature is -15°C, where the inverter should stop charging and the BMS should forcibly turn off the charging MOS.
BIT14	MOSFET high temperature alarm	The warning MOS over-temperature is 90°C, where the inverter should stop charging and discharging and the BMS should not turn off the charging and discharging MOS.
BIT15	Low SOC alarm	The warning low battery SOC is less than 5%, where the inverter should stop discharging and the BMS should not turn off the charging and discharging MOS and should not alarm during charging.

6.3.2 BMS Protection codes and description

0x340 DATE4 , 5	Protecting Flag	Troubleshooting
BIT0	Battery cell overvoltage protection	The unit overcharging protection voltage is 3700mV, where the inverter should stop charging and the BMS should forcibly turn off the charging MOS.
BIT1	Battery cell under-voltage protection	The unit over discharge protection voltage is 2500mV, where the inverter should stop discharging and the BMS should forcibly turn off the discharging MOS. After 30 seconds of over discharge protection, if the battery still cannot be restored, it will enter a low power consumption mode.
BIT2	Battery PACK overvoltage protection	The overall overcharge protection voltage is 59V, where the inverter should stop charging and the BMS should turn off the charging MOS.
BIT3	Battery PACK under-voltage protection	The overall over discharge protection voltage is 40V, where the inverter should stop discharging and the BMS should forcibly turn off the discharging MOS. After 30 seconds of over discharge protection, if the battery still cannot be restored, it will enter a low power consumption mode.
BIT4	Charging overcurrent protection	The protective limit of charging overcurrent is 120A, where the BMS should forcibly turn off the charging MOS. This state will be locked and not be exited automatically if it occurs continuously for 10 times.
BIT5	Discharging overcurrent protection	The protective limit of discharging overcurrent 1 is 130A and the protective limit of discharging overcurrent 2 is 200A with a delay of 100ms, where the BMS should forcibly turn off the discharging MOS. This state will be locked and not be exited automatically if it occurs continuously for 10 times.
BIT6	Short circuit current protection	The short circuit protection current is no less than 350A with a delay of 300us, where the BMS should forcibly turn off the discharging MOS.
BIT7	Charging overvoltage protection	The overall overcharge protection voltage is 59V, where the inverter should stop charging and the BMS should turn off the charging MOS.
BIT8	Charging high temperature protection (cell temperature)	The protective limit of charging high temperature is 57°C, where the BMS should forcibly turn off the charging MOS.
BIT9	Discharging high temperature protection (cell temperature)	The protective limit of discharging high temperature is 57°C, where the BMS should forcibly turn off the discharging MOS.
BIT10	Charging low temperature protection (cell temperature)	The protective limit of charging low temperature is 0°C, where the BMS should forcibly turn off the charging MOS.
BIT11	Discharging low temperature protection (cell temperature)	The protective limit of discharging low temperature is -20°C, where the BMS should forcibly turn off the discharging MOS.
BIT12	MOSFET high temperature protection	The protective limit of MOS over-temperature is 110°C, where the BMS should forcibly turn off the charging and discharging MOS.
BIT13	High ambient temperature protection	The protective limit of high ambient temperature is 70°C, where the BMS should forcibly turn off the charging and discharging MOS.
BIT14	Low ambient temperature protection	The protective limit of low ambient temperature is -25°C, where the BMS should forcibly turn off the charging and discharging MOS.
BIT15	Heating function fault	Reset the battery PACK; If the fault is not clear, contact the service engineer.

6.3.3 BMS Fault codes and description

0x340 DATE6 , 7	Status/Fault Flag	Troubleshooting
-----------------------	-------------------	-----------------

BIT0	Charging MOSFET malfunction	Restart the battery PACK, if the fault still exists, contact the manufacturer and lock it until the technical personnel resolve the problem.
BIT1	Discharging MOSFET malfunction	Restart the battery PACK, if the fault still exists, contact the manufacturer and lock it until the technical personnel resolve the problem.
BIT2	Temperature sensor malfunction	Restart the battery PACK, if the fault still exists, contact the manufacturer and lock it until the technical personnel resolve the problem.
BIT3	Cell voltage sampling fault	Reset the battery PACK; If the fault is not clear, contact the service engineer.
BIT4	Battery cell malfunction	Restart the battery PACK, if the fault still exists, contact the manufacturer and lock it until the technical personnel resolve the problem.
BIT5	Front-end sampling communication failure	Restart the battery PACK, if the fault still exists, contact the manufacturer and lock it until the technical personnel resolve the problem.
BIT6	Heating control Mosfet fault	Reset the battery PACK; If the fault is not clear, contact the service engineer.
BIT7	Reserved	
BIT8	Reserved	
BIT9	Reserved	
BIT10	Reserved	
BIT11	Reserved	
BIT12	Reserved	
BIT13	Reserved	
BIT14	Reverse DC connection	Check whether or not the wiring between the battery PACK and the positive and negative wires of the inverter battery is proper.
BIT15		

7 Storing and Recharging Batteries

7.1 Storage Environment Requirements

It is recommended that you begin using the battery soon after delivery rather than store the battery pack for a long time. The maximum storage life of a battery pack is three years.

The intended storage environment of the battery pack should meet these requirements:

- Ambient temperature: -20°C to 45°C.
- Recommended storage temperature: 20°C to 30°C.
- Relative humidity: 0–95% (No condensation).
- Dry, ventilated, and clean area.
- No contact with corrosive organic solvents, gases, and other substances.
- No direct sunlight.
- More than two meters from any heat source.

 **WARNING**

When storing a battery in its packaging, make sure that the packaging box is intact and that the battery is appropriately placed and stacked, and the above mentioned requirements are met.

7.2 Interval for Recharging Batteries

While in storage, batteries must be recharged at specified intervals.

Actual Storage Temperature	Interval
$0^{\circ}\text{C} \leq T \leq 35^{\circ}\text{C}$	6 months

If a battery is deformed, broken or leaking, discard it immediately regardless of its storage time.

Lithium-ion batteries lose capacity during storage. After 12 months of storage at the intended storage temperature, the capacity generally falls irreversibly by 3–10%. Batteries with less than 100% capacity after storage cannot pass the discharge testing and acceptance testing.

7.3 Recharging a Battery

If a battery has not been charged for two weeks or more after a deep discharge, or the SOC of a battery is less than 50% after a long period of storage, the battery must be charged to 50%.

WARNING

Before charging the battery, check it for deformation, case damage, or leakage, and if you find any of these things, do not charge the battery.



If the SOC of a battery pack is not less than 50% after more than 12 months of storage, it is not necessary to recharge the battery.

NOTES

Prepare a cross screwdriver and insulated rubber gloves.

CAUTION

When you connect the power wires, wear insulated rubber gloves.

PROCEDURE

Step 1. Connect power cables to the battery charger correctly. The maximum number of battery pack connected parallel is 8.

Step 2. Press the battery “start key” for 1~3 seconds to start the battery pack. Check the LED on the battery “start key” is on, then switch the 2-Pole DC Circuit breaker to the “NO” position.

Step 3. Turn on the battery charger.

Step 4. Set charging parameter on the battery charger.

Case #1, One battery pack is charged. Set the charge limited voltage 57.6V; Set the charge limited current 80A;

Case #2, Two battery packs are charged. Set the charge limited voltage 57.6V; Set the charge limited current 160A;

Case #3, Three ~ Eight battery packs are charged. Set the charge limited voltage 57.6V; Set the charge limited current 240A;

Step 5. After the battery is charged, switch off the battery charger and press the battery “start key” for 1~3 seconds to switch off the battery pack.

8 Disposal

When the system reaches the end of its service life, follow these steps to dispose of the equipment:

Step 1. Uninstall the system:

- 1.1 Disconnect all power sources.
- 1.2 Disassemble all parts of the system from top to bottom.

Step 2. Dispose of all the parts. **DO NOT** dispose of the battery packs as regular household waste.



This symbol means that the labeled equipment must not be disposed of as regular household waste. It must be disposed of at an electrical and electronic equipment-recycling center.

NOTICE

If you need to replace a battery pack, you should request a new dangerous goods package, pack the battery pack, and then have the supplier pick it up.

KSTAR New Energy does not recycle batteries. Please contact your local recycling organization for disposal. If there is no local recycling organization, you should contact the nearest recycling organization in your country.

9 Specifications

Battery Model	BP48100PF 1A-G2	BP48100P F1A-G2-2P	BP48100P F1A-G2-3P	BP48100P F1A-G2-4P	BP48100P F1A-G2-5P	BP48100P F1A-G2-6P	BP48100P F1A-G2-7P	BP48100P F1A-G2-8P
General Parameters								
Battery Type	LFP (LiFePO4)							
Cell Brand	EVE							
Rated Capacity	100Ah	200Ah	300Ah	400Ah	500Ah	600Ah	700Ah	800Ah
Energy Capacity	5.12 kWh ¹⁾	10.24kWh	15.36kWh	20.48kWh	25.6kWh	30.72kWh	35.84kWh	40.96kWh
Usable Capacity	5.01 kWh	10.03kWh	15.05kWh	20.07kWh	25.09kWh	30.10kWh	35.12kWh	40.14kWh
Max.Depth of Discharge	98%							
Norminal Voltage	51.2 V							
Operating Voltage Range	44.8 ~ 57.6 V							
Battery Pack Round-Trip Efficiency	>94%							
Weight	50.5 kg	101kg	151.5kg	202kg	252.5kg	303kg	353.5kg	404kg
Dimensions (WxHxD, include base and head-cover and decorative cover)(mm)	725*465.5*245	725*835.5*245	725*1205.5*245	725*1575.5*245	1450*1357*245	1450*1357*245	1450*1727*245	1450*1727*245
Installation Site	Outdoor/Indoor							
Max. Operation Altitude	≤ 2000 m							
Protective Class	Class I							
Over Voltage Category DC	OVC II							
Pollution Degree	PD2(Internal); PD3(External)							
IP Protection	IP65							
Warranty	10 Years							
Operation								
Max. charging current (A d.c.)	80 A	160A	240A	240A	240A	240A	240A	240A
Rated DC Charging Power	4096 W	8192W	12288W	12288W	12288W	12288W	12288W	12288W
Max. discharging current (A d.c.)	80 A	160A	240A	240A	240A	240A	240A	240A
Rated DC Charging Power	4096 W	8192W	12288W	12288W	12288W	12288W	12288W	12288W
Operating Temperature Range	-10 to 50°C (Charging); -10 to 50°C (Discharging)							
Cooling Type	Natural Cooling							
Humidity	0 ~ 90%							
BMS								
Modules Connection	Max. 8							
Communication	CAN / RS485							
Monitoring Parameters	System v voltage,current,battery v voltage,Battery temperature,PCBA temperature measurement							
Certificate								
Country of Manufacture	China							
Safety and Transportation	Pack:IEC/EN 62619; UN38.3; IEC 62477; IEC 62040; IEC 61000 Cell:IEC/EN 62619; UN38.3; UL1973;							
1) Total Energy Capacity is tested under the following conditions: @25°C, 0.5C charging/0.5C discharging, at the beginning of life.								

A

AC	Alternating Current
AFCI	Arc-Fault Circuit-Interrupter
App	Application
AWG	American Wire Gauge

B

BESS	Battery Energy Storage System
BMS	Battery Management System

C

CT	Current Transformer
----	---------------------

D

DC	Direct Current
DOD	Depth of Discharge
DRED	Demand Response Enabling Device
DRM	Demand Response Mode
DSP	Digital Signal Processor

E

EMI	Electromagnetic Interference
EMS	Energy Management System
EPS	Emergency Power Supply

G

GFCI	Ground Fault Circuit Interrupter
------	----------------------------------

I

ISO	Insulation
-----	------------

M

MPPT	Maximum Power Point Tracker
------	-----------------------------

P

PV	Photovoltaic
----	--------------

R

RCD	Residual Current Device
RESP	Response
RRCR	Radio Ripple Control Receiver

S

SCI	Serial Communication Interface
SOC	State of Charge